

OMRON



Components Catalogue



Welcome	7 - 8
POWER RELAYS	9 - 156
Technical Information – Power & Signal Relays	9 - 28
Selection Guide	29 - 40
G5B	41 - 44
G5NB-E	45 - 48
G5SB	49 - 52
G6M	53 - 56
G6D	57 - 60
G6B	61 - 67
G2RG	68 - 71
G5Q-EU	72 - 75
G6RN	76 - 79
G5LE	80 - 84
G5LC-EU	85 - 88
G5C(E)	89 - 92
G6C	93 - 101
G2R	102 - 122
G2RL	123 - 127
G4W	128 - 132
G8P	133 - 138
G4A	139 - 142
G9EA-1	143 - 149
G9EC-1	150 - 156



SIGNAL RELAYS	157 - 273
Selection Guide	157 - 165
G5V-1	166 - 168
G2E	169 - 172
G6E	173 - 177
G6L	178 - 186
G6H	187 - 192
G6J	193 - 202
G6K	203 - 212
G6S	213 - 221
G5A	222 - 225
G5V-2	226 - 230
G6A	231 - 239
G6Y	240 - 245
G6K(U)-RF	246 - 249
G6Z	250 - 265
G6W	266 - 273



AUTOMOTIVE RELAYS	274 - 313
Selection Guide	274 - 277
G8N-1	278 - 282
G8ND-2	283 - 287
G8NW	288 - 292
G8QN	293 - 294
G8SN	295 - 296
G8SE	297 - 298
G8HN-J	299 - 304
G8HL	305 - 309
G8JN	310 - 311
G8JR	312 - 313



SOLID STATE RELAYS	314 - 347
Technical Information	314 - 318
Selection Guide	319 - 323
G3R/G3RD	324 - 327
G3M	328 - 331
G3MB	332 - 334
G3MC	335 - 339
G3S/G3SD	340 - 343
G3DZ	344 - 347



MOSFET RELAYS	348 - 433
Technical Information	348 - 351
Selection Guide	352 - 357
G3VM-61A1/D	358 - 359
G3VM-2(F)L	360 - 361
G3VM-351A/D	362 - 363
G3VM-353A/D	364 - 365
G3VM-401A/D	366 - 367
G3VM-61G1	368 - 369
G3VM-81G1	370 - 371
G3VM-201G	372 - 373
G3VM-351G	374 - 375
G3VM-353G	376 - 377
G3VM-401G	378 - 379
G3VM-61B1/E1	380 - 381
G3VM-XN(F)	382 - 384
G3VM-351B/E	385 - 386

G3VM-3(F)L	387 - 388
G3VM-353B/E	389 - 390
G3VM-401B/E	391 - 392
G3VM-4N(F)	393 - 395
G3VM-401BY/EY	396 - 397
G3VM-601BY/EY	398 - 399
G3VM-61H1	400 - 401
G3VM-201H1	402 - 403
G3VM-351H	404 - 405
G3VM-353H	406 - 407
G3VM-401H	408 - 409
G3VM-62C1/F1	410 - 411
G3VM-352C/F	412 - 413
G3VM-W(F)L	414 - 415
G3VM-354C/F	416 - 417
G3VM-355C/F	418 - 419
G3VM-402C/F	420 - 421
G3VM-62J1	422 - 423
G3VM-202J1	424 - 425
G3VM-352J	426 - 427
G3VM-354J	428 - 429
G3VM-355J	430 - 431
G3VM-402J	432 - 433



GENERAL PURPOSE RELAYS	434 - 508
Technical Information	434 - 439
Selection Guide	440 - 442
MY	443 - 455
LY	456 - 468
G2RS	469 - 478
G7L	479 - 493
G7J	494 - 502
G7SA	503 - 508



MICROSWITCHES	509 - 659
Technical Information	509 - 520
Selection Guide	521 - 530
D3V	531 - 544
V	545 - 560
VX	561 - 567
SS	568 - 575

SS-P	576 - 581
SSG	582 - 589
D2F	590 - 595
D2MQ	596 - 600
D3C	601 - 604
D2X	605 - 608
D3K	609 - 612
D3M	613 - 618
D2SW	619 - 624
D2VW	625 - 630
D2JW	631 - 635
D2HW	636 - 644
D2MC	645 - 649
D2D	650 - 657
D3D	658 - 661



DIP SWITCHES	662 - 690
Technical Information	662 - 664
Selection Guide	665 - 668
A6H	669 - 670
A6T/A6S	671 - 673
A6D/A6DR	674 - 676
A6E/A6ER	677 - 679
A6A	680 - 683
A6C/A6CV	684 - 686
A6R/A6RV	687 - 690



TACTILE SWITCHES	691 - 731
Technical Information	691 - 693
Selection Guide	694 - 698
B3F	699 - 707
B3W	708 - 711
B3FS	712 - 714
B3SN	715 - 716
B3S	717 - 718
B3WN	719 - 720
B3J	721 - 723
B3DA	724 - 725
B3D	726 - 729
B32	730 - 731



PHOTOMICROSENSORS	732 - 914
Technical Information	732 - 736
Selection Guide	737 - 738
EE-SX1107	739 - 743
EE-SX1018	744 - 746
EE-SX1108	747 - 751
EE-SX1131	752 - 756
EE-SX1139	757 - 759
EE-SX4139	760 - 762
EE-SX493	763 - 765
EE-SX1055	766 - 768
EE-SX1046	769 - 771
EE-SX1082	772 - 774
EE-SX1106	775 - 777
EE-SX1109	778 - 782
EE-SX199	783 - 785
EE-SX398/498	786 - 788
EE-SV3	789 - 791
EE-SX1071	792 - 794
EE-SX1088	795 - 797
EE-SH3	798 - 800
EE-SJ3	801 - 803
EE-SX3088/4088	804 - 806
EE-SG3	807 - 809
EE-SX1128	810 - 812
EE-SX1041	813 - 815
EE-SX1042	816 - 818
EE-SX1081	819 - 821
EE-SX1235A-P2	822 - 824
EE-SX4009-P1	825 - 827
EE-SX4019-P2	828 - 830
EE-SX3081/4081	831 - 833
EE-SX4009-P10	834 - 836
EE-SX4235A-P2	837 - 839
EE-SX1070	840 - 842
EE-SX3070/4070	843 - 845
EE-SPX415-P2	846 - 848
EE-SX461-P11	849 - 852
EE-SX414-P1	853 - 855
EE-SA102	856 - 858
EE-SA103	859 - 861

EE-SA104	862 - 864
EE-SA107-P2	865 - 867
EE-SA407-P2	868 - 870
EE-SY124	871 - 873
EE-SY125	874 - 876
EE-SY193	877 - 881
EE-SY171	882 - 884
EE-SY169B	885 - 887
EE-SY113	888 - 890
EE-SY313/413	891 - 894
EE-SF5-B	895 - 897
EE-SY110	898 - 900
EE-SY310/410	901 - 904
Z4D-B01	905 - 908
EY3A-312	909 - 911
EY3A-112	912 - 914



LEDs	915 - 921
2MDR	915 - 921

SPECIAL SENSORS	922 - 935
D6B	922 - 923
D6A-N	924 - 926
D8M-A1	927 - 928
D8M-D82	929 - 930
D6F	931 - 933
D7E	934 - 935



CONNECTORS	936 - 968
XF2E	936 - 937
XF2H	938 - 939
XF2J	940 - 941
XF2L	942 - 943
XG4M-U	944 - 946
XG4	947 - 954
XM4	955 - 957
XH2	958 - 964
XM7	965 - 968

PART NUMBER INDEX	969 - 971
--------------------------	------------------

Welcome to the Omron Components Catalogue

Omron Components is a world-class business delivering a wide range of high quality, high performance components utilising latest technologies and backed by full technical, applications and logistical support.

We offer the widest range of relays for power, signal and automotive applications as well as solid-state and MOSFET relays. Our G3VM MOSFETS combine

the advantages of mechanical and solid-state technologies allowing design flexibility with either AC or DC load able to be connected in either direction. We are also developing our range of microsensors, and currently offer photomicrosensors and a new range of D8M-D8 micro pressure-sensors which meet stringent safety standards such as working reliably with low pressure, metal casing and flange fitting. Our broad range of switches includes micro, DIP, and tactile options, and you will find a wide selection of connectors to meet

industry-standard data interconnect, power transmission and signalling. Omron Double Reflection LEDs feature built-in optical light guide technology that more than doubles effective light output compared with conventional bullet-type LEDs.



Environmental research and experience enabled us to formulate a policy to remove recognised hazardous substances from our products well within the timescales of European Directives. We have identified suitable alternative materials and agreed the changes we need to make to our production processes in order to maintain quality levels. All of our manufacturing sites have achieved ISO14001 certification for the management of environmental protection in our organisation.



Using our website alongside this catalogue, you can be kept fully up-to-date with our range of products, technical capabilities and environmental policy.

www.eu.omron.com/ocb

Omron Electronic Components Europe B.V. reserves the right to make any changes to the specifications, technical information and data of the components described in this catalogue at its sole discretion without prior notice

Although we do strive for perfection, Omron Electronic Components Europe B.V. does not warrant or make any representations regarding the correctness or accuracy of the specifications, technical information and data of the components as described in this catalogue.

(All dimensions in mm)

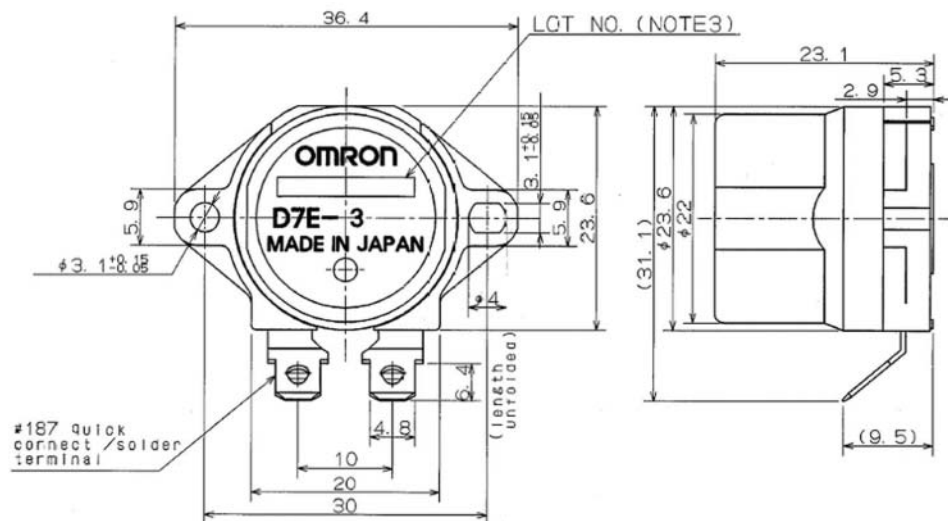

ALL DIMENSIONS SHOWN ARE IN MILLIMETERS.
To convert millimeters into inches, multiply by 0.03937. To convert grams into ounces, multiply by 0.03527.

Optimum low-profile design (SMT Terminal).
Ultra-low-profile FPC/FFC connector only 1.5mm above the PCB.

- Side-entry
- Ultra-low-profile only 1.5 mm on the PCB allows mounting in spaces with restricted height.
- 0.8 mm-pitch SMT connectors allow high-density mounting.
- Modified-PA-resin housing is compatible with VPS, IR reflow, etc
- Double-sided contacts maintain a stable contact force.
- Standard tape packing compatible with automatic mounting.

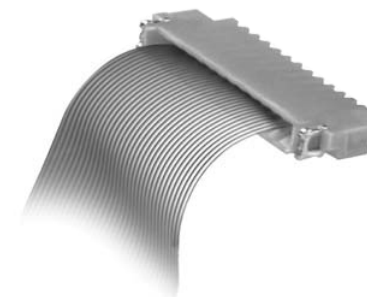

Specifications

Rated Current	0.5A
Rated Voltage	50 VDC
Contact resistance	30 mΩ max. (max. 20 mV, max. 100 mA)
Insulation resistance	100 MΩ min. (at 100 VDC)
Withstand voltage	500 VAC 1 min. (leakage current: 1 mA max.)
Total insertion force	Poles x 2.0 N (200 gf) max.
Total removal force	Poles x 0.3 N (200 gf) max.
Insertion tolerance	10 times
Ambient temperature	-30 to +85°C (No condensation at low temperatures.)

Materials/Finish

Housing	Modified PA resin containing glass (UL94V-0)/opal
Contact	Copper-alloy/nickel spring substrate (2μm) plated with tin alloy (2μm)
Hold Down	Copper-alloy/copper substrate (2μm) plated with tin alloy (2μm)

Ordering Information

Poles	Model	Poles	Model	Quantity per reel*
5	XF2E-0515-1	10	XFE-1015-1	4,000
6	XF2E-0615-1	12	XFE-1215-1	
7	XF2E-0715-1	15	XFE-1515-1	
8	XF2H-0815-1	17	XFE-1715-1	

*Order an integer multiple of the quantity per reel.

■ Dimensions

XF2E-□□15-1 (SMT Terminal)

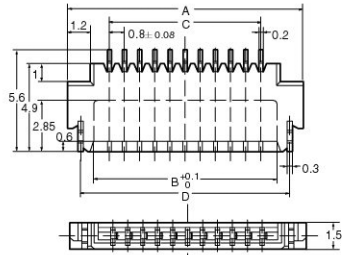

Printed Circuit Board Matching Dimension (Top View)

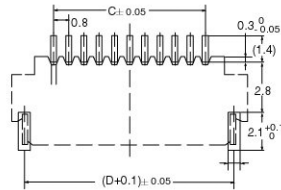

Applicable FPC Dimensions

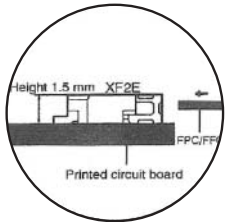
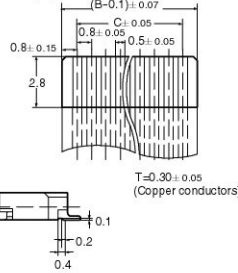

■ Mounted Image

■ Table of Dimensions

Poles	Model	A	B	C	D
5	XF2E-0515-1	7.6	4.9	3.2	6.2
6	XF2E-0615-1	8.4	5.7	4	7
7	XF2E-0715-1	9.2	6.5	4.8	7.8
8	XF2E-0815-1	10	7.3	5.6	8.6
10	XF2E-1015-1	11.6	8.9	7.2	10.2
12	XF2E-1215-1	13.2	10.5	8.8	11.8
15	XF2E-1515-1	15.6	12.9	11.2	14.2
17	XF2E-1715-1	17.2	14.5	12.8	15.8

ALL DIMENSIONS SHOWN ARE IN MILLIMETERS.

To convert millimeters into inches, multiply by 0.03937. To convert grams into ounces, multiply by 0.03527.

New rotary – lock concept achieves high reliability and superior work efficiency.

- The unique rotary lock construction significantly improves work efficiency during FPC mounting.
- Double –sided contacts maintain a stable contact force.
- Discrimination between FPC upper and lower contacts is unnecessary.
- Low-profile, protruding only 2 mm on the PCB.



Specifications

■ Specifications

Rated Current	0.5A
Rated Voltage	50 VDC
Contact resistance	30 mΩ max. (max. 20 mV, max. 100 mA)
Insulation resistance	100 MΩ min. (at 250 VDC)
Withstand voltage	250 VAC 1 min. (leakage current: 1 mA max.)
Insertion tolerance	20 times
Ambient temperature	-30 to +85°C (No condensation at low temperatures.)

■ Materials/Finish

Housing	PA46 resin (UL94V-0)/natural
Slider	LCP resin (UL94V-0)/black
Contact	Copper-alloy/nickel spring substrate (2μm) plated with tin alloy (2μm)
Hold Down	Copper-alloy/copper substrate (2μm) plated with tin alloy (2μm)

■ Ordering Information

Poles	Model	Poles	Model	Quantity per reel*
10	XF2H-1015-1	26	XF2H-2615-1	1,500
12	XF2H-1215-1	30	XF2H-3015-1	
13	XF2H-1315-1	34	XF2H-3415-1	
14	XF2H-1415-1	35	XF2H-3515-1	
18	XF2H-1815-1	38	XF2H-3815-1	
20	XF2H-2015-1	40	XF2H-4015-1	
22	XF2H-2215-1	45	XF2H-4515-1	
24	XF2H-2415-1	50	XF2H-5015-1	

*Order an integer multiple of the quantity per reel.

■ Dimensions

XF2H-□□15-1

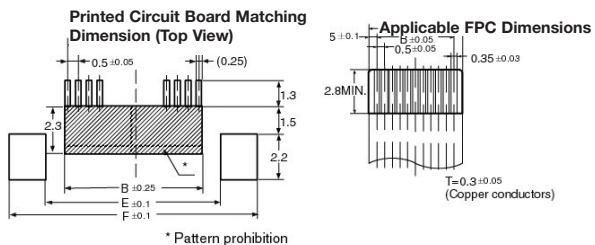
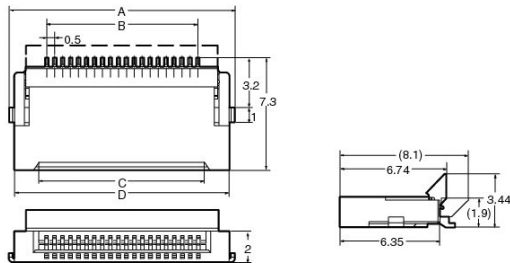

■ Table of Dimensions

Poles	Model	A	B	C	D	E	F
10	XF2H-1015-1	9.1	4.5	5.6	8.5	6.5	10.1
12	XF2H-1215-1	10.1	5.5	6.6	9.5	7.5	11.1
13	XF2H-1315-1	10.6	6	7.1	10	8	11.6
14	XF2H-1415-1	11.1	6.5	7.6	10.5	8.5	12.1
18	XF2H-1815-1	13.1	8.5	9.6	12.5	10.5	14.1
20	XF2H-2015-1	14.1	9.5	10.6	13.5	11.5	15.1
22	XF2H-2215-1	15.1	10.5	11.6	19.5	12.5	16.1
24	XF2H-2415-1	16.1	11.5	12.6	15.5	13.5	17.1
26	XF2H-2615-1	17.1	12.5	13.6	16.5	14.5	18.1
30	XF2H-3015-1	19.1	14.5	15.6	18.5	16.5	20.1
34	XF2H-3415-1	21.1	16.5	17.6	20.5	18.5	22.1
35	XF2H-3515-1	21.6	17	18.1	21	19	22.6
38	XF2H-3815-1	23.1	18.5	19.6	22.5	20.5	24.1
40	XF2H-4015-1	24.1	19.5	20.6	23.5	21.5	25.1
45	XF2H-4515-1	26.6	22	23.1	26	24	27.6
50	XF2H-5015-1	29.1	24.5	25.8	28.5	26.5	30.1

ALL DIMENSIONS SHOWN ARE IN MILLIMETERS.
To convert millimeters into inches, multiply by 0.03937. To convert grams into ounces, multiply by 0.03527.

Top-entry ZIF Connector

- Slider achieves secure locking.
- Low-profile, protruding only 4.15 mm on the PCB.
- Adhesion face on top of the connector suits automatic mounting.



Specifications

■ Specifications

Rated Current	0.5A
Rated Voltage	50 VDC
Contact resistance	30 mΩ max. (max. 20 mV, max. 100 mA)
Insulation resistance	100 MΩ min. (at 100 VDC)
Withstand voltage	250 VAC 1 min. (leakage current: 1 mA max.)
Insertion tolerance	30 times
Ambient temperature	-30 to +85°C (No condensation at low temperatures.)

■ Materials/Finish

Housing	PA46 resin (UL94V-0)/natural
Slider	PPS resin (UL94V-0)/black
Contact	Copper-alloy/nickel spring substrate (2μm) plated with tin alloy (2μm)
Hold Down	Copper-alloy/copper substrate (2μm) plated with tin alloy (2μm)

■ Ordering Information

Poles	Model	Quantity per reel*
6	XF2J-0624-11	1,000
8	XF2J-0824-11	
10	XF2J-1024-11	
12	XF2J-1224-11	
14	XF2J-1424-11	
16	XF2J-1624-11	
18	XF2J-1824-11	
20	XF2J-2024-11	
22	XF2J-2224-11	
24	XF2J-2424-11	
26	XF2J-2624-11	
28	XF2J-2824-11	
30	XF2J-3024-11	

*Order an integer multiple of the quantity per reel.

■ Dimensions

XF2J-□□24-11

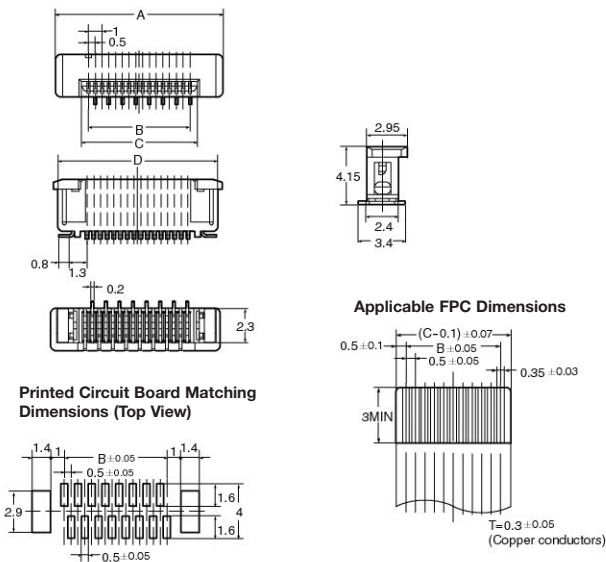

■ Table of Dimensions

Poles	Model	A	B	C	D
6	XF2J-0624-11	7.5	2.5	3.6	6.9
8	XF2J-0824-11	8.5	3.5	4.6	7.9
10	XF2J-1024-11	9.5	4.5	5.6	8.9
12	XF2J-1224-11	10.5	5.5	6.6	9.9
14	XF2J-1424-11	11.5	6.5	7.6	10.9
16	XF2J-1624-11	12.5	7.5	8.6	11.9
18	XF2J-1824-11	13.5	8.5	9.6	12.9
20	XF2J-2024-11	14.5	9.5	10.6	13.9
22	XF2J-2224-11	15.5	10.5	11.6	14.9
24	XF2J-2424-11	16.5	11.5	12.6	15.9
26	XF2J-2624-11	17.5	12.5	13.6	16.9
28	XF2J-2824-11	18.5	13.5	14.6	17.9
30	XF2J-3024-11	19.5	14.5	15.6	18.9

Industry – smallest on-board area and low-profile construction enhance board design freedom.

- Occupies smallest on-board area in the industry.
- Low profile only 1.2 mm max. above the board.
- The connectors on the lower surface do not protrude from the rear of the connector face, achieving highest board-design efficiency in the industry.
- Secure locking



Specifications

■ Specifications

Rated Current	0.5A
Rated Voltage	50 VDC
Contact resistance	30 mΩ max. (max. 20 mV, max. 100 mA)
Insulation resistance	100 MΩ min. (at 250 VDC)
Withstand voltage	250 VAC 1 min. (leakage current: 1 mA max.)
Insertion tolerance	20 times
Ambient temperature	-30 to +85°C (No condensation at low temperatures.)

■ Materials/Finish

	Upper Contact Type	Lower Contact Type
Housing	LCP Resin (UL94V-0)/natural	LCP Resin (UL94V-0)/natural
Slider	LCP resin (UL94V-0)/black	LCP resin (UL94V-0)/brown
Contact	Copper -alloy/nickel spring substrate (2μm) plated with tin alloy (2μm)	
Hold-down	Copper-alloy/Hot-dip silver plated	

■ Ordering Information

Poles	Type	Model	Poles	Type	Model	Quantity per reel*
4	Upper Contact	XF2L-0425-1	13	Upper Contact	XF2L-1325-1	3,000
5	Lower Contact	XF2L-0535-1		Lower Contact	XF2L-1335-1	
6	Upper Contact	XF2L-0625-1	15	Upper Contact	XF2L-1535-1	
7	Upper Contact	XF2L-0725-1		18	Lower Contact	
	Lower Contact	XF2L-0735-1	20		Upper Contact	
8	Upper Contact	XF2L-0825-1		21	Lower Contact	
	Lower Contact	XF2L-0835-1	22		Lower Contact	XF2L-2235-1
10	Upper Contact	XF2L-1025-1		26	Upper Contact	XF2L-2625-1
12	Lower Contact	XF2L-1235-1	30		Upper Contact	XF2L-3025-1
					Lower Contact	XF2L-3035-1

*Order an integer multiple of the quantity per reel.

■ Dimensions

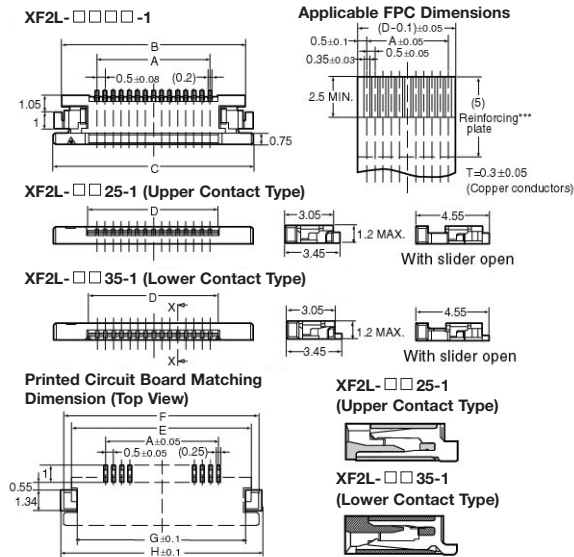

■ Table of Dimensions

Upper Contact Type

Poles	Model	A	B	C	D	E	F	G	H
4	XF2L-0425-1	1.5	5.9	6.9	2.6	5.88	6.88	5.28	7.28
6	XF2L-0625-1	2.5	6.9	7.9	3.6	6.88	7.88	6.28	8.28
7	XF2L-0725-1	3	7.4	8.4	4.1	7.38	8.38	6.78	8.78
8	XF2L-0825-1	3.5	7.9	8.9	4.6	7.88	8.88	7.28	9.28
10	XF2L-1025-1	4.5	8.9	9.9	5.6	8.88	9.88	8.28	10.28
13	XF2L-1325-1	6	10.4	11.4	7.1	10.38	11.38	9.78	11.78
21	XF2L-2125-1	10	14.4	15.4	11.1	14.38	15.38	13.78	15.78
26	XF2L-2625-1	12.5	16.9	17.9	13.6	16.88	17.88	16.28	18.28
30	XF2L-3025-1	14.5	18.9	19.9	15.6	18.88	19.88	18.28	20.28

Upper Contact Type

Poles	Model	A	B	C	D	E	F	G	H
5	XF2L-0535-1	2	6.4	7.4	3.1	6.38	7.38	5.78	7.78
7	XF2L-0735-1	3	7.4	8.4	4.1	7.38	7.38	6.78	8.78
8	X2FL-0835-1	3.5	7.9	8.9	4.6	7.88	8.88	7.28	9.28
12	XF2L-1235-1	5.5	9.9	10.9	6.6	9.88	10.88	9.28	11.28
13	XF2L-1335-1	6	10.4	11.4	7.1	10.38	11.38	9.78	11.78
15	XF2L-1535-1	7	11.4	12.4	8.1	11.38	12.38	10.78	12.78
18	XF2L-1835-1	8.5	12.9	13.9	9.6	12.88	13.88	12.28	14.28
20	XF2L-2035-1	9.5	13.9	14.9	10.6	13.88	14.88	13.28	15.28
22	XF2L-2235-1	10.5	14.9	15.9	11.6	14.88	15.88	14.28	16.28
30	XF2L-3035-1	14.5	18.9	19.9	15.6	18.88	19.88	18.28	20.28

Easier Circuit Board Wiring Connections

■ Can Be Connected and Disconnected With One Hand

A new function that integrates a lock lever into the socket enables the connector to be connected and disconnected with one hand even in confined or difficult-to-operate spaces. These connectors are easier to handle than conventional MIL flat cable connectors. This alleviates the worker load, in particular, when many connectors must be connected and disconnected.

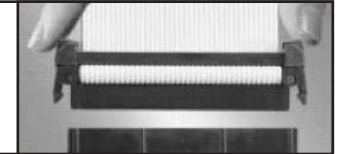

■ Improved Lock Lever Operation

A metal spring is used for the lock lever to improve lock lever operability. The lock lever is designed to directly grip the socket body during unlocking. So, now the connector can be easily connected and disconnected by a single-action operation.

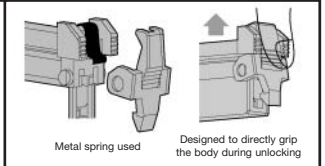

■ Same Locking Strength as Conventional Models

The connector uses a new lock mechanism that grips the cable inwards when it is tugged. A locking strength of 15 kgf or more (performance value) is assured, achieving high contact reliability.

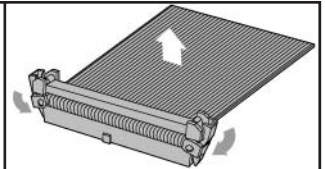

■ New cable flex-resistant lock mechanism

Details of Combinations

1. Socket lock type combination XG4C + XG4M + XG4U
2. Lever lock type (conventional model) combination XG4A + XG4M + XG4T
3. Simple lock type XG4C + XG4M + XG4Z

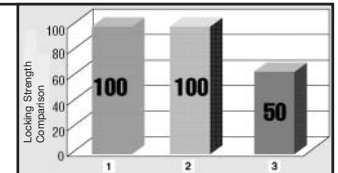

■ Suitable for Configuring Compact, Space-saving Devices

Board Occupied Space Reduced by 24%

Board occupied space is reduced by approx. 24% compared with lever lock types (in-house comparison) when unlocked and by approx. 17% when locked. This also allows circuit boards to be more compact.

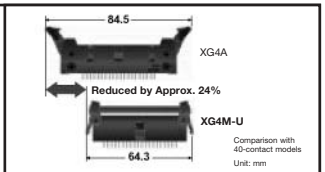

Mounting Height Reduced by 24%

The mounting height is reduced by approx. 24% compared with lever lock types (in-house comparison), which helps make devices thinner.

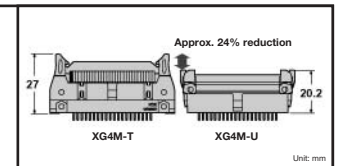

■ Dimensions

Note: All units are in millimeters unless otherwise indicated.

Strain relief (with lock)
XG4U

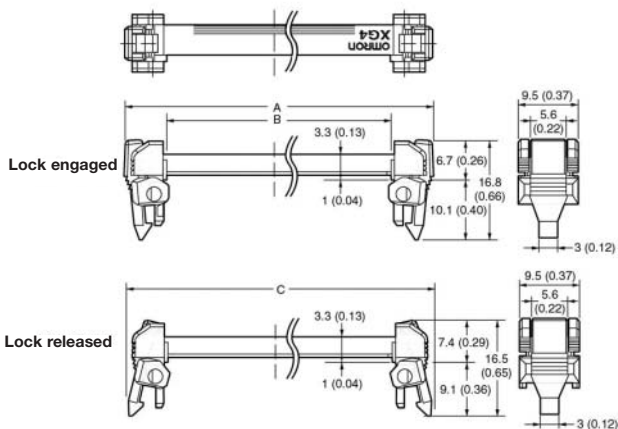

Socket (with open-end cover)

XG4M-□□30 (one polarity guide)
XG4M-□□31 (all others)

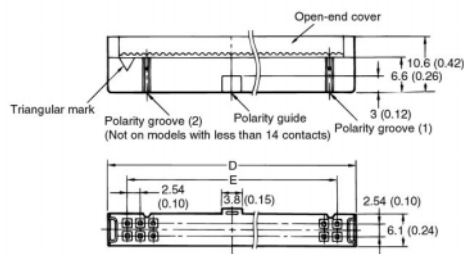
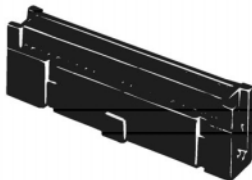

■ Mated Dimensions

Note: All units are in millimeters unless otherwise indicated.

XG4U and XG4M and XG4C (straight terminal)

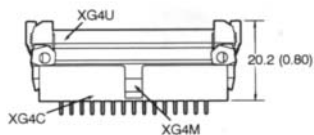

XG4U and XG4M and XG4C (right-angle terminal)

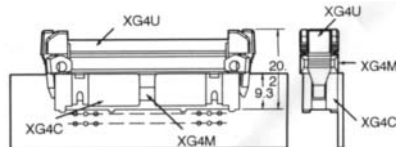

Ordering Information

No. of contacts	Model			Dimensions [mm (ins.)]					Polarity guides
	Set*	Socket** (with open-end cover)	Strain relief (with lock)	A	B	C	D	E	
10	XG4M-1031-U	XG4M-1031	XG4U-1004	26.8 (1.06)	13.2 (0.52)	26.2 (1.03)	17.3 (0.68)	10.16 (0.40)	0
	XG4M-1030-U	XG4M-1030							1
14	XG4M-1430-U	XG4M-1430	XG4U-1404	31.8 (1.25)	18.2 (0.72)	31.2 (1.23)	22.3 (0.88)	15.24 (0.60)	1
16	XG4M-1630-U	XG4M-1630	XG4U-1604	34.4 (1.35)	20.8 (0.82)	33.8 (1.33)	24.9 (0.98)	17.78 (0.70)	1
20	XG4M-2030-U	XG4M-2030	XG4U-2004	39.5 (1.56)	25.9 (1.02)	38.9 (1.53)	30.0 (1.18)	22.86 (0.90)	1
26	XG4M-2630-U	XG4M-2630	XG4U-2604	47.1 (1.85)	33.5 (1.32)	46.5 (1.83)	37.6 (1.48)	30.48 (1.20)	1
30	XG4M-3030-U	XG4M-3030	XG4U-3004	52.2 (2.06)	38.6 (1.52)	51.6 (2.03)	42.7 (1.68)	35.56 (1.40)	1
34	XG4M-3430-U	CG4M-3430	XG4U-3404	57.2 (2.25)	43.6 (1.72)	56.6 (2.23)	47.7 (1.88)	40.64 (1.60)	1
40	XG4M-4030-U	XG4M-4030	XG4U-4004	64.9 (2.56)	51.3 (2.02)	64.3 (2.53)	55.4 (2.18)	48.26 (1.90)	1
50	XG4M-5030-U	XG4M-5030	XG4U-5004	77.6 (3.06)	64.0 (2.52)	77.0 (3.03)	68.1 (2.68)	60.96 (2.40)	1
	XG4M-5031-U	XG4M-5031							2***
60	XG4M-6030-U	XG4M-6030	XG4U-6004	90.3 (3.56)	76.7 (3.02)	89.7 (3.53)	80.8 (3.18)	73.66 (2.90)	1
	XG4M-6031-U	XG4M-6031							2***
64	XG4M-6430-U	XG4M-6430	XG4U-6404	95.3 (3.75)	81.7 (3.22)	94.7 (3.73)	85.8 (3.38)	78.74 (3.10)	1
	XG4M-6431-U	XG4M-6431							2***

* With open-end cover

** Strain relief available separately

*** Polarity guide pitch is 22.86 mm (0.911 in.).

ALL DIMENSIONS SHOWN ARE IN MILLIMETERS.



To convert millimeters into inches, multiply by 0.03937. To convert grams into ounces, multiply by 0.03527.

The mainstream of circuit board connectors, meeting MIL standards with improved design.

- With our new production system, we have improved the reliability and decreased the cost.
- Space-saving box-type plug (XG4C) available.
- The (XG4C) can be locked using the lock lever.
- Conforms to MIL standards (MIL-C-83503)
- UL standard component (file no. E103202)

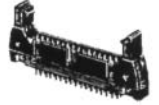

Ordering Information

	XG4A	XG4C
Appearance	MIL-type Plug 	Box-type Plug 

■ Recommended Wires

IDC
1.27mm (0.050in.) pitch flat cable AWG28 (strand wire).

■ Ratings/Characteristics

Rated current	1 A (at 20°C)
Rated voltage	250 VAC
Contact resistance	20 mΩ max. (at 20 mV, 100 mA max.)
Insulation resistance	1,000 MΩ min. (at 500 VDC)
Withstand voltage	500 VAC for 1 min. (leakage current 1 mA max.)
Connector insertion	200 gf (0.44 lb.f) max. per terminal
Contact removal	40 gf (0.088 lb.f) min. (test gauge with 0.64-mm (0.025-in.))
Usage durability	50 times min.
Operating temperature	-55°C to 105°C

■ Materials/Finish

Item	MIL-type plug XG4A. Box-type plug XG4C
Housing	PBT resin with glass (UL94V-0)/ black
Contact	Moving end Brass/nickel base, 0.15 μm gold plated*
	Terminal Brass/nickel base, 0.2 μm tin plated

*For standard 0.15μm gold plating.

MIL Type Plug with Long Lock – XG4A

■ Dimensions

XG4A-□□31/□□71 (Straight dip terminals)

XG4A-□□34/□□74 (Right-angle dip terminals)

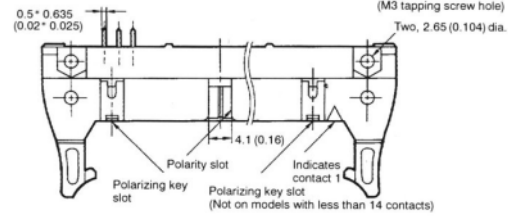
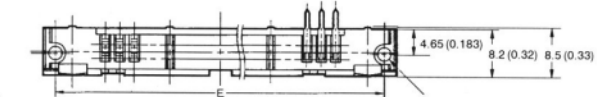
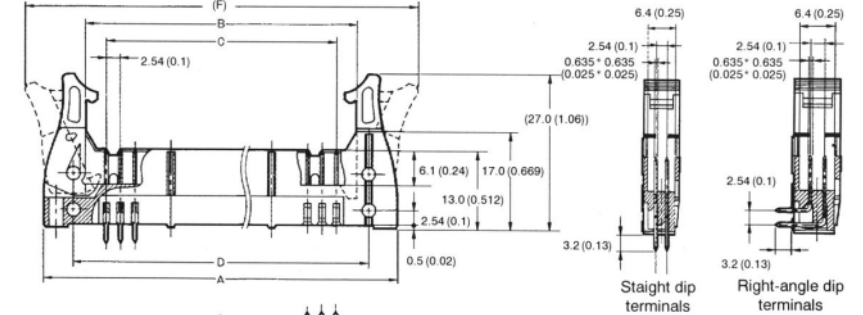
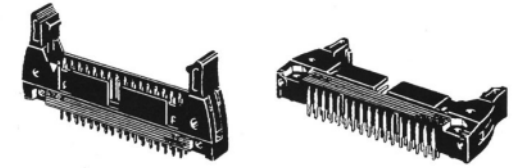

Mounting View (bottom view)

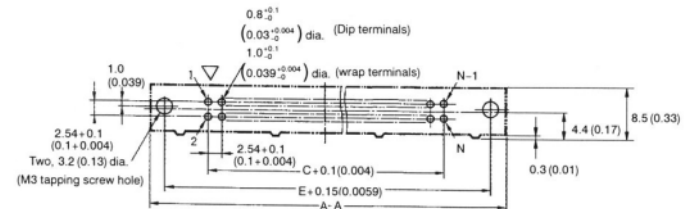
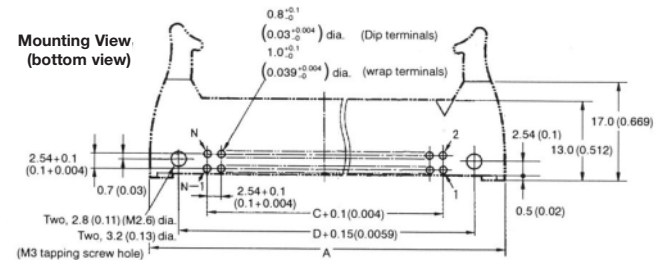

MIL Type Plug with Long Lock – XG4A

Ordering Information

Use in combination with strain-relief sockets.

No. of contacts	Model			Dimensions [mm (ins.)]					Polarity guides
	Set*	Socket** (with open-end cover)	Strain relief (with lock)	A	B	C	D	E	
10	XG4A-1071	XG4A-1074	32.0 (1.26)	17.5 (0.69)	10.16 (0.4)	21.8 (0.86)	27.9 (1.1)	38.8 (1.53)	0
	XG4A-1031	XG4A-1034							1
14	XG4A-1431	XG4A-1434	37.1 (1.46)	22.6 (0.89)	15.24 (0.6)	26.9 (1.06)	33.0 (1.3)	43.9 (1.73)	1
16	XG4A-1631	XG4A-1634	39.6 (1.56)	25.2 (0.99)	17.78 (0.7)	29.5 (1.16)	35.6 (1.4)	46.5 (1.83)	1
20	XG4A-2031	XG4A-2034	44.7 (1.76)	30.2 (1.19)	22.86 (0.9)	34.5 (1.36)	40.6 (1.6)	51.5 (2.03)	1
26	XG4A-2631	XG4A-2634	52.3 (2.06)	37.9 (1.49)	30.48 (1.2)	42.2 (1.66)	48.3 (1.9)	59.2 (2.33)	1
30	XG4A-3031	XG4A-3034	57.4 (2.26)	42.9 (1.69)	35.56 (1.4)	47.2 (1.86)	53.3 (2.1)	64.2 (2.53)	1
34	XG4A-3431	XG4A-3434	62.5 (2.46)	48.0 (1.89)	40.64 (1.6)	52.3 (2.06)	58.4 (2.3)	69.3 (2.73)	1
40	XG4A-4031	XG4A-4034	70.1 (2.76)	55.6 (2.19)	48.26 (1.9)	59.9 (2.36)	66.0 (2.6)	76.9 (3.03)	1
50	XG4A-5031	XG4A-5034	82.8 (3.26)	68.3 (2.69)	60.96 (2.4)	72.6 (2.86)	78.7 (3.1)	89.6 (3.53)	1
	XG4A-5071	XG4A-5074							2
60	XG4A-6031	XG4A-6034	95.5 (3.76)	81.0 (3.19)	73.66 (2.9)	85.3 (3.36)	91.4 (3.6)	102.3 (4.03)	1
	XG4A-6071	XG4A-6074							2
64	XG4A-6431	XG4A-6434	100.6 (3.96)	86.1 (3.39)	78.74 (3.1)	90.4 (3.56)	96.5 (3.8)	107.4 (4.23)	1
	XG4A-6471	XG4A-6474							2

MIL Type Plug with Short Lock – XG4A

■ Dimensions

XG4A-□□32/□□72 (Straight dip terminals)

XG4A-□□35/□□75 (Right-angle dip terminals)

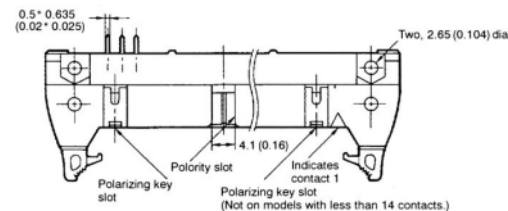
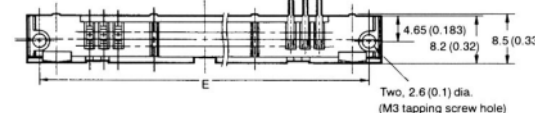
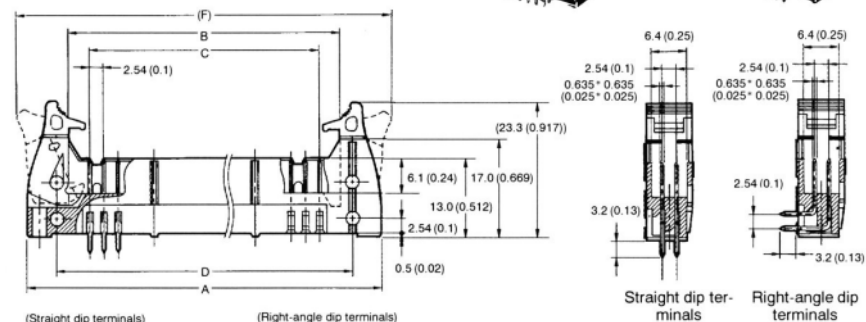
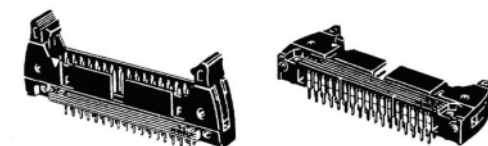

Mounting Holes (bottom view)

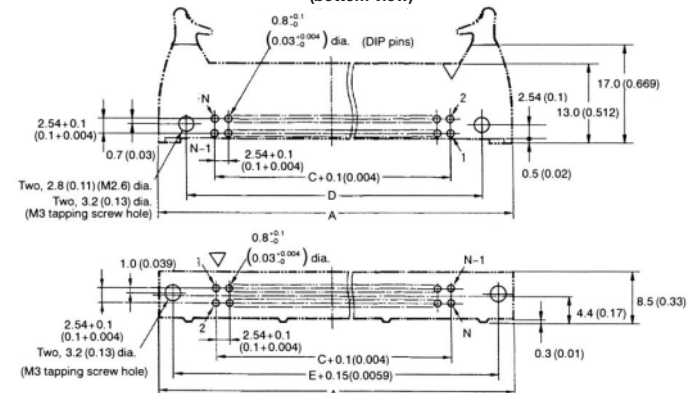

MIL Type Plug with Short Lock – XG4A

Ordering Information

Use in combination with non-strain-relief sockets.

No. of contacts	Model		Dimensions [mm (ins.)]						Polarity slots
	Straight Dip Terminals	Right-angle Dip terminals	A	B	C	D	E	F	
10	XG4A-1072	XG4A-1075	32.0 (1.26)	17.5 (0.69)	10.16 (0.4)	21.8 (0.86)	27.9 (1.1)	35.8 (1.41)	0
	XG4A-1032	XG4A-1035							1
14	XG4A-1432	XG4A-1435	37.1 (1.46)	22.6 (0.89)	15.24 (0.6)	26.9 (1.06)	33.0 (1.3)	40.9 (1.61)	1
16	XG4A-1632	XG4A-1635	39.6 (1.56)	25.2 (0.99)	17.78 (0.7)	29.5 (1.16)	35.6 (1.4)	43.5 (1.71)	1
20	XG4A-2032	XG4A-2035	44.7 (1.76)	30.2 (1.19)	22.86 (0.9)	34.5 (1.36)	40.6 (1.6)	48.5 (1.91)	1
26	XG4A-2632	XG4A-2635	52.3 (2.06)	37.9 (1.49)	30.48 (1.2)	42.2 (1.66)	48.3 (1.9)	56.2 (2.21)	1
30	XG4A-3032	XG4A-3035	57.4 (2.26)	42.9 (1.69)	35.56 (1.4)	47.2 (1.86)	53.3 (2.1)	61.2 (2.41)	1
34	XG4A-3432	XG4A-3435	62.5 (2.46)	48.0 (1.89)	40.64 (1.6)	52.3 (2.06)	58.4 (2.3)	66.3 (2.61)	1
40	XG4A-4032	XG4A-4035	70.1 (2.76)	55.6 (2.19)	48.26 (1.9)	59.9 (2.36)	66.0 (2.6)	73.9 (2.91)	1
50	XG4A-5032	XG4A-5035	82.8 (3.26)	68.3 (2.69)	60.96 (2.4)	72.6 (2.86)	78.7 (3.1)	86.6 (3.41)	1
	XG4A-5072	XG4A-5075							2
60	XG4A-6032	XG4A-6035	95.5 (3.76)	81.0 (3.19)	73.66 (2.9)	85.3 (3.36)	91.4 (3.6)	99.3 (3.91)	1
	XG4A-6072	XG4A-6075							2
64	XG4A-6432	XG4A-6435	100.6 (3.96)	86.1 (3.39)	78.74 (3.1)	90.4 (3.56)	96.5 (3.8)	104.4 (4.11)	1
	XG4A-6472	XG4A-6475							2

Type	Model
Long lock	XG4Z-0010
Short lock	XG4Z-0011

Box-type – XG4C

■ Dimensions

Box type
XG4C-□□31/□□1071
(Straight dip terminals)

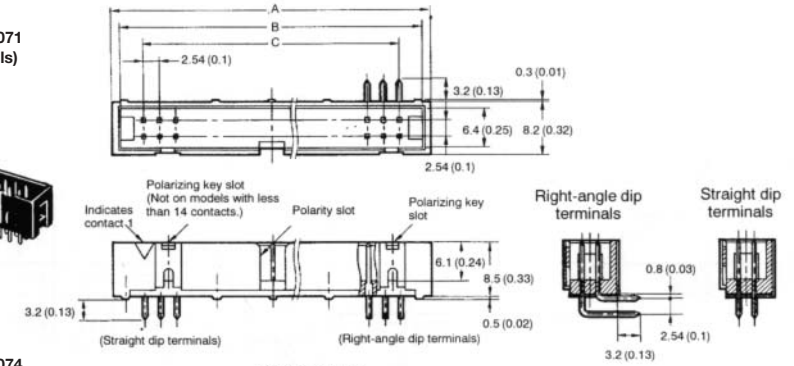
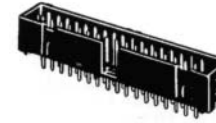

XG4C-□□31/□□1074
(Right-angle dip terminals)

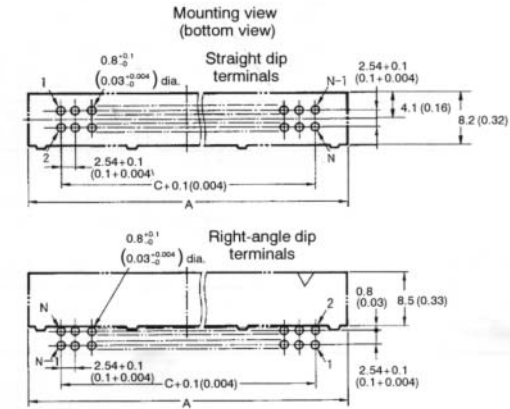
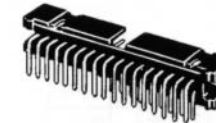

Box-type – XG4C

Ordering Information

No. of contacts	Polarity store	Model		Dimensions [mm (ins.)]		
		Straight dip terminals	Right-angle dip terminals	A	B	C
10	0	XG4C-1071	XG4C-1074	20.0 (0.79)	17.5 (0.69)	10.16 (0.4)
	1	XG4C-1031	XG4C-1034			
14	1	XG4C-1431	XG4C-1434	25.1 (0.99)	22.6 (0.89)	15.24 (0.6)
16	1	XG4C-1631	XG4C-1634	27.6 (1.09)	25.2 (0.99)	17.78 (0.7)
20	1	XG4C-2031	XG4C-2034	32.7 (1.29)	30.2 (1.19)	22.86 (0.9)
26	1	XG4C-2631	XG4C-2634	40.3 (1.59)	37.9 (1.49)	30.48 (1.2)
30	1	XG4C-3031	XG4C-3034	45.4 (1.79)	42.9 (1.69)	35.56 (1.4)
34	1	XG4C-3431	XG4C-3434	50.5 (1.99)	48.0 (1.89)	40.64 (1.6)
40	1	XG4C-4031	XG4C-4034	58.1 (2.29)	55.6 (2.19)	48.26 (1.9)
50	1	XG4C-5031	XG4C-5034	70.8 (2.79)	68.3 (2.69)	60.96 (2.4)
	2	XG4C-5071	XG4C-5074			
60	1	XG4C-6031	XG4C-6034	83.5 (3.29)	81.0 (3.19)	73.66 (2.9)
	2	XG4C-6071	XG4C-6074			
64	1	XG4C-6431	XG4C-6434	88.6 (3.49)	86.1 (3.39)	78.74 (3.1)
	2	XG4C-6471	XG4C-6474			

Note: The box-type plug can be locked using lock lever II (sold separately.)

■ Cable Number and Contact Position

Cable and corresponding contact no.

The contact numbers are not printed on the connector. Use the triangular mark as a guide when wiring and designing circuit boards.

For the cable number, count starting from the cable mark side as shown below.

XG4A

2-level type right-angle terminal plug (terminal side)

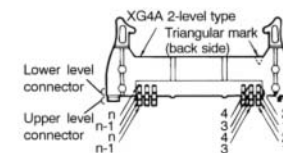

XG4M

Socket (mating side)

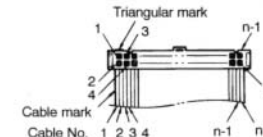

XG4A

Right-angle terminal plug (terminal side)

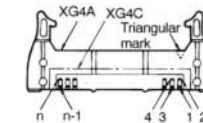

XG4A

Straight terminal plug (terminal side)

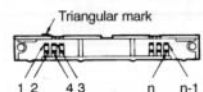

■ Mated Dimensions

XG4U and XG4M and XG4C
(Straight terminal)

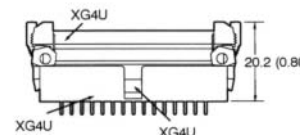

XG4U and XG4M and XG4C
(Right-angle terminal)

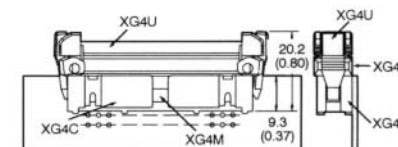

Precautions

Manufacturing tools, polarity slots and polarizing keys are available depending on model. Please contact Omron for more information.

Conditions for automatic soldering (jet type)

Soldering temperature: 250°C ± 5°C

Continuous soldering period: 5 seconds or less

Handling of XG4U

Do not use or store XG4U's in an environment condensed with magnetic particles.

ALL DIMENSIONS SHOWN ARE IN MILLIMETERS.

To convert millimeters into inches, multiply by 0.03937. To convert grams into ounces, multiply by 0.03527.

High-density Connectors Ideal for Interfacing with Electronic Devices

- High-density construction with 15 poles in a standard 9-pole general-purpose shell.
- Shielded connectors that prevent EMI.



	Right angle terminal XM4L-1542-132	Right angle terminal XM4L-1542-502	Straight terminal XM4L-1541-132	Straight terminal XM4L-1541-502
Shape				
Part number	XM4L-1542-132	XM4L-1542-502	XM4L-1541-132	XM4L-1541-502
M.O.Q	90	90	90	90

M.O.Q: Minimum Order Quantity

■ Specifications

Rated Current	3A
Rated Voltage	250 VAC
Contact resistance	20mΩ max. (max.20mΩ, max 100mA)
Insulation resistance	5000MΩ min. (at 500 VDC)
Withstand voltage	1000 VAC 1 min. (leakage current: 1 mA max.)
Insertion force	max. 58.8N
Pulling out force	min. 13.7N
Insertion tolerance	100 times
Ambient temperature	-25 to +105°C (No condensation at low temperatures.)

■ Materials/Finish

Housing	PBT resin with glass (UL94V-0) / black
Contact	Nickel spring substrate / flash plating
Shell	Copper / Tin plating

■ Dimensions

XM4L-1542-132
XM4L-1542-502

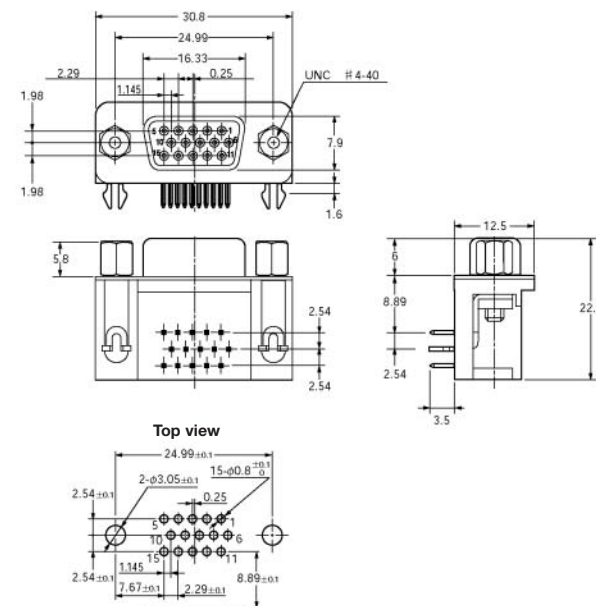

XM4L-1541-132
XM4L-1541-502

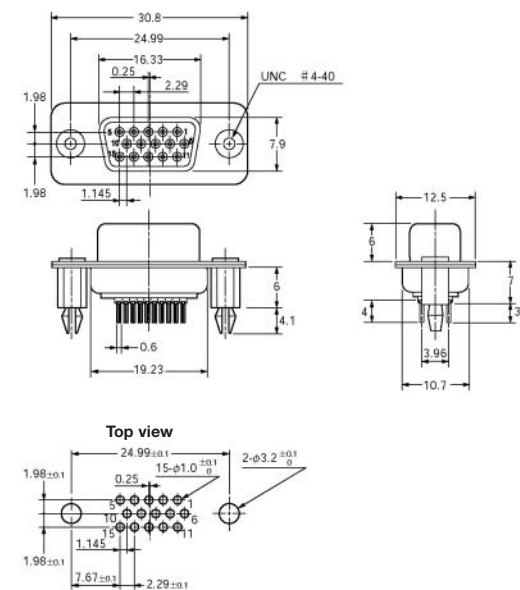

■ Accessories

Sell separately.

XM4Z-0023
XM4Z-1023
(inch screws #4-40UNC)

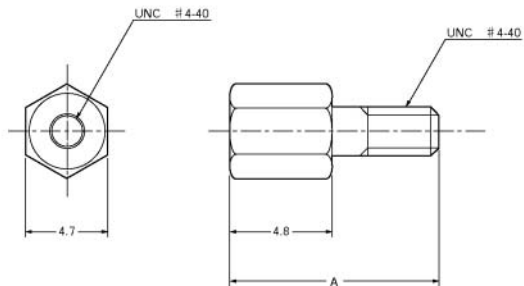

This accessory is used for attaching connector and ??????.
Thickness of adaptor is 0.6 – 1.3mm.

■ Materials/Finish

Materials/Finish	Copper alloy / nickel plate
Packaging	Small box / 500 p.c.s

Part number	A (mm)	Connector
XM4Z-0023	11.8	XM4L-1542-502
XM4Z-1023	10.0	XM4L-1541-502

Note: XM4Z-0023 – Right angle terminal
XM4Z-1023 – Straight terminal

Auto soldering

Condition for auto soldering:

1. Soldering temperature : 250 ±5°C
2. Continuous soldering time: max. 5 seconds

Panel	Without screw fixation	With screw fixation
Setscrew	Setscrew 2	Setscrew3 or inch screw (#4-40UNC)

ALL DIMENSIONS SHOWN ARE IN MILLIMETERS.

To convert millimeters into inches, multiply by 0.03937. To convert grams into ounces, multiply by 0.03527.

Allows high-density mounting for electronic devices.

A half-pitch connector with a pitch of 1.27 mm (0.05 in.) for compactness.

- A pitch of 1.27 mm (0.05 in.) for high-density mounting of double-row arrangements.
- A quadruple-row staggered arrangement (1.27 mm x 1.905 mm) (0.05 in. x 0.075 in.) for board connection.
- The bellows contact design, enables smooth mating and resistance to bending.
- Space saving mating length of 3.1 mm (0.12 in.).
- Positive contact locking assures long-term contact quality. The gold/palladium plating has been improved for better contact reliability.
- A special finish prevents flux rise. Also it has fastening pins to standardize all the terminals.

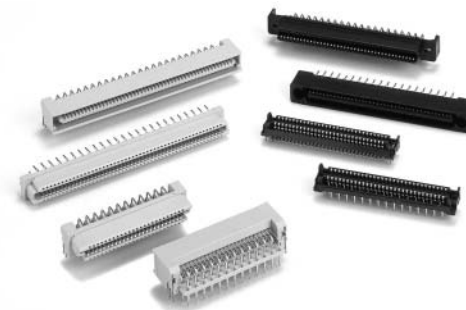

Specifications

■ Ratings/Characteristics

Rated current	0.5 A (at 20°C)
Contact resistance*	30 mΩ max. (at 20 mV, 100 mA max.)
Insulation resistance	10 ⁹ mΩ min. (at 500 VDC)
Withstand voltage	650 VAC for 1 min. (leakage current 1 mA max.)
Connector insertion	80 gf (0.18 lb.f) max. per contact
Connector removal	10 gf (0.022 lb.f) max. per contact
Usage durability	400 times min.
Operating temperature	-55 to 105°C

*For XH2A-□□42 and XH2B-□□41.

Materials and Finish

Item		Plug	Socket
Housing		PBT resin with glass (UL94V-0) (black)	
Locator		PBT resin with glass (UL94V-0) (black)	
Contact	Mating end	Phosphor bronze/nickel base, gold/palladium plating	Phosphor bronze/nickel base, gold/palladium plating
	Terminal	Phosphor bronze/nickel base, copper plating (2mm)	Phosphor bronze/nickel base, copper plating (2mm)
Fastening pins		Phosphor bronze/copper plating	

Mating Diagram

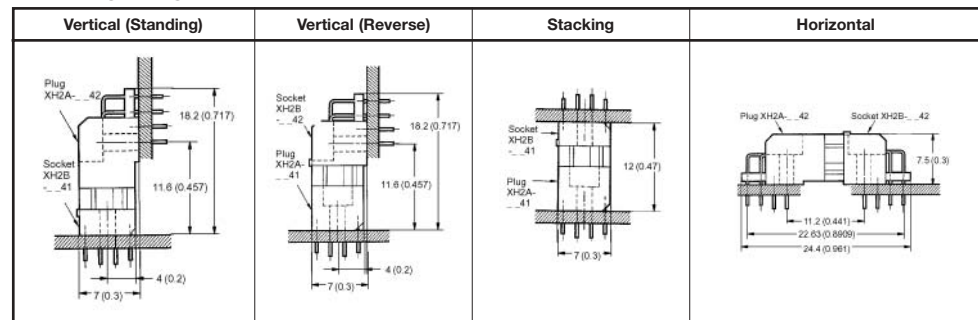

* The standard and reverse models function as the standard DIN connectors (XC5).

XH2A Plugs, Straight Dip Terminals

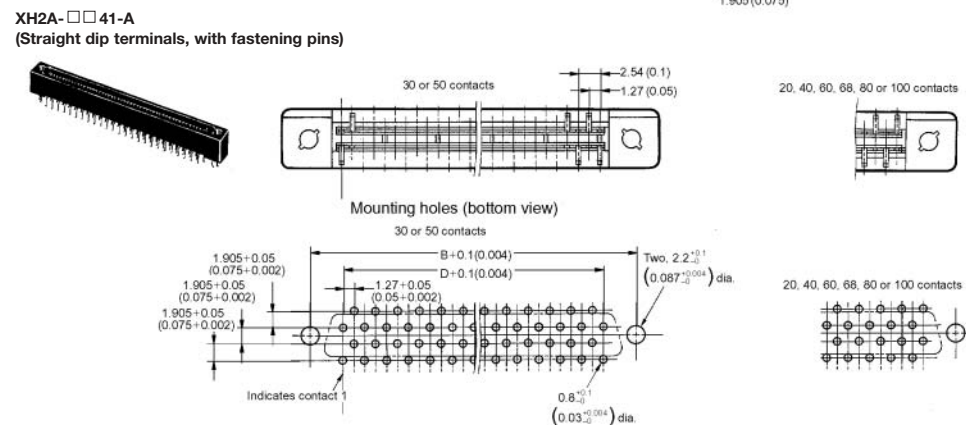
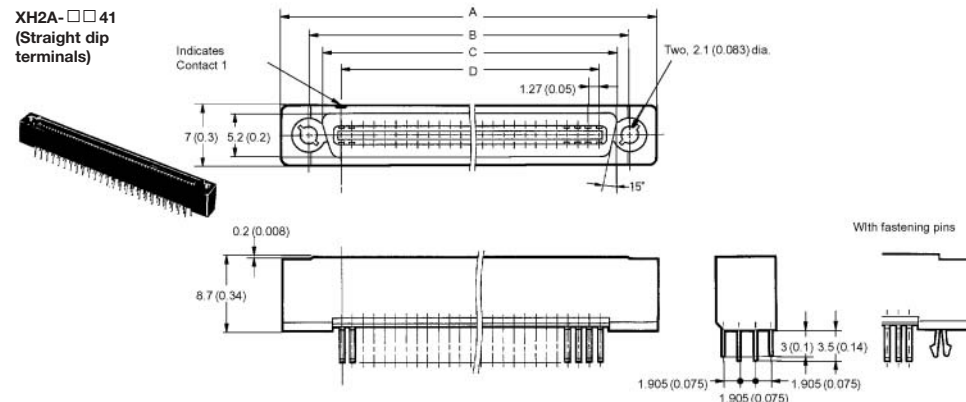

Ordering Information

No. of contacts	Model		Dimensions [mm (ins.)]			
	Plug/Straight dip terminals	Plug/Straight dip terminals with fastening pins	A	B	C	D
20	XH2A-2041	XH2A-2041-A	25.4 (1)	19.05 (0.75)	15.8 (0.622)	11.43 (0.45)
30	XH2A-3041	XH2A-3041-A	31.8 (1.25)	25.40 (1)	22.2 (0.874)	17.78 (0.7)
40	XH2A-4041	XH2A-4041-A	38.1 (1.5)	31.75 (1.25)	28.5 (1.12)	24.13 (0.95)
50	XH2A-5041	XH2A-5041-A	44.5 (1.75)	38.10 (1.5)	34.9 (1.37)	30.48 (1.2)
60	XH2A-6041	XH2A-6041-A	50.8 (2) 44.	45 (1.75)	41.2 (1.62)	36.83 (1.45)
68	XH2A-6841	XH2A-6841-A	55.9 (2.2)	49.53 (1.95)	46.3 (1.82)	41.91 (1.65)
80	XH2A-8041	XH2A-8041-A	63.5 (2.5)	57.15 (2.25)	53.9 (2.12)	49.53 (1.95)
100	XH2A-0141	XH2A-0141-A	76.2 (3)	69.85 (2.75)	66.6 (2.62)	62.23 (2.45)

■ XH2A Plugs, Right-angle Dip Terminals

XH2A-□□42
(Right-angle dip terminals)

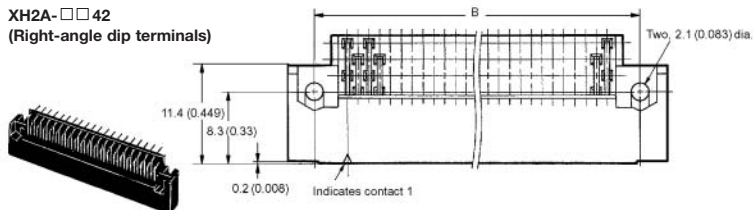

XH2A-□□42-A
(Right-angle dip terminals, with fastening pins)

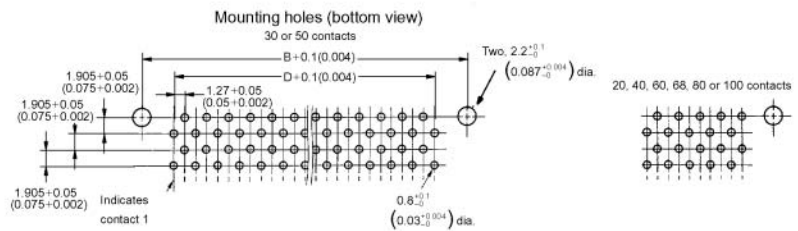
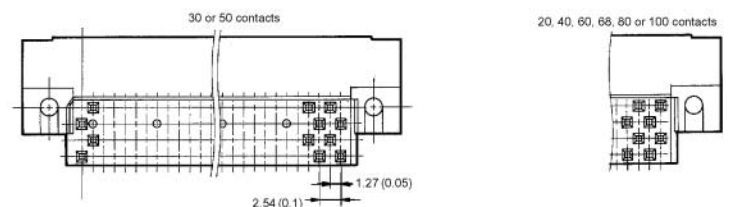
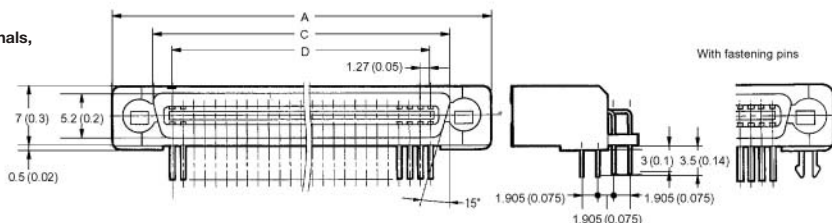

Ordering Information

No. of contacts	Model		Dimensions [mm (ins.)]			
	Plug/Straight dip terminals	Plug/Straight dip terminals with fastening pins	A	B	C	D
20	XH2A-2042	XH2A-2042-A	25.4 (1)	19.05 (0.75)	15.8 (0.622)	11.43 (0.45)
30	XH2A-3042	XH2A-3042-A	31.8 (1.25)	25.40 (1)	22.2 (0.874)	17.78 (0.7)
40	XH2A-4042	XH2A-4042-A	38.1 (1.5)	31.75 (1.25)	28.5 (1.12)	24.13 (0.95)
50	XH2A-5042	XH2A-5042-A	44.5 (1.75)	38.10 (1.5)	34.9 (1.37)	30.48 (1.2)
60	XH2A-6042	XH2A-6042-A	50.8 (2)	44.45 (1.75)	41.2 (1.62)	36.83 (1.45)
68	XH2A-6842	XH2A-6842-A	55.9 (2.2)	49.53 (1.95)	46.3 (1.82)	41.91 (1.65)
80	XH2A-8042	XH2A-8042-A	63.5 (2.5)	57.15 (2.25)	53.9 (2.12)	49.53 (1.95)
100	XH2A-0142	XH2A-0142-A	76.2 (3)	69.85 (2.75)	66.6 (2.62)	62.23 (2.45)

■ XH2A Sockets, Straight Dip Terminals

XH2B-□□41
(Straight dip terminals)

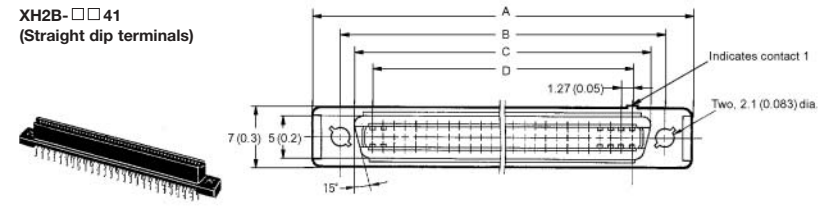

XH2B-□□41-A
(Straight dip terminals, with fastening pins)

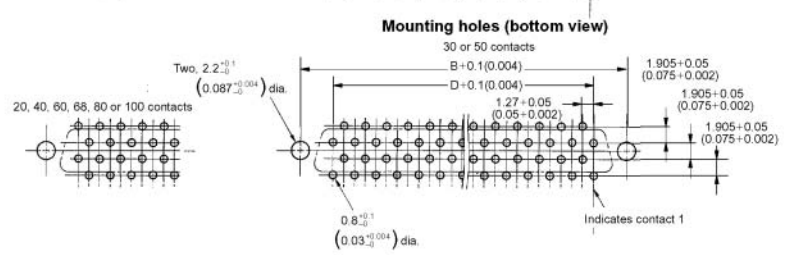
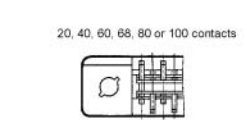
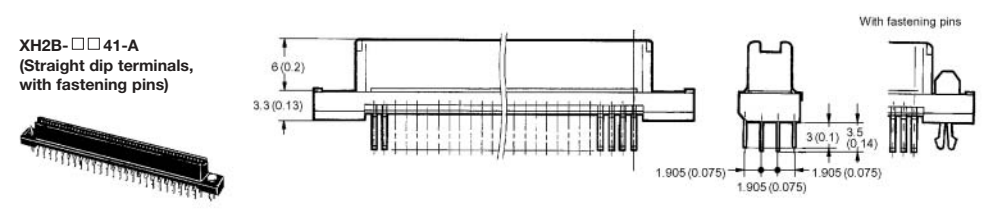

Ordering Information

No. of contacts	Model		Dimensions [mm (ins.)]			
	Plug/Straight dip terminals	Plug/Straight dip terminals with fastening pins	A	B	C	D
20	XH2B-2041	XH2B-2041-A	25.4 (1)	19.05 (0.75)	15.7 (0.618)	11.43 (0.45)
30	XH2B-3041	XH2B-3041-A	31.8 (1.25)	25.40 (1)	22.1 (0.87)	17.78 (0.7)
40	XH2B-4041	XH2B-4041-A	38.1 (1.5)	31.75 (1.25)	28.4 (1.12)	24.13 (0.95)
50	XH2B-5041	XH2B-5041-A	44.5 (1.75)	38.10 (1.5)	34.8 (1.37)	30.48 (1.2)
60	XH2B-6041	XH2B-6041-A	50.8 (2)	44.45 (1.75)	41.1 (1.62)	36.83 (1.45)
68	XH2B-6841	XH2B-6841-A	55.9 (2.2)	49.53 (1.95)	46.2 (1.82)	41.91 (1.65)
80	XH2B-8041	XH2B-8041-A	63.5 (2.5)	57.15 (2.25)	53.8 (2.12)	49.53 (1.95)
100	XH2B-0141	XH2B-0141-A	76.2 (3)	69.85 (2.75)	66.5 (2.62)	62.23 (2.45)

■ XH2A Sockets, Right-angle Dip Terminals

XH2B-□□42
(Right-angle dip terminals)

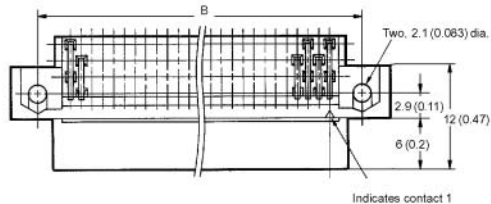

XH2B-□□42-A
(Right-angle dip terminals, with fastening pins)

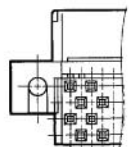
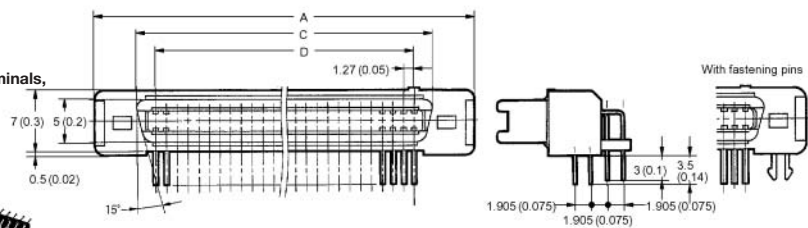

20, 40, 60, 80, or 100 contacts

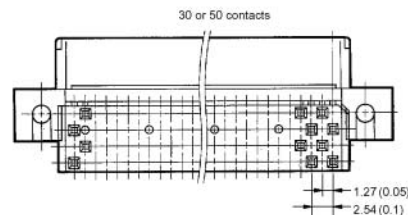

Mounting holes (bottom view)

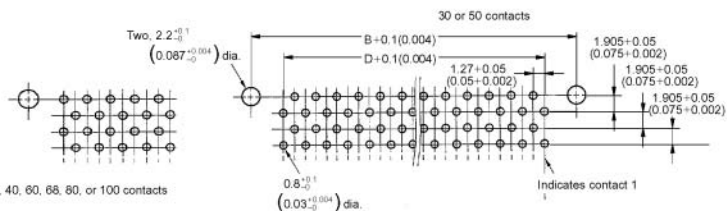

20, 40, 60, 80, or 100 contacts

Ordering Information

No. of contacts	Model		Dimensions [mm (ins.)]			
	Plug/Straight dip terminals	Plug/Straight dip terminals with fastening pins	A	B	C	D
20	XH2B-2042	XH2B-2042-A	25.4 (1)	19.05 (0.75)	15.7 (0.618)	11.43 (0.45)
30	XH2B-3042	XH2B-3042-A	31.8 (1.25)	25.40 (1)	22.1 (0.87)	17.78 (0.7)
40	XH2B-4042	XH2B-4042-A	38.1 (1.5)	31.75 (1.25)	28.4 (1.12)	24.13 (0.95)
50	XH2B-5042	XH2B-5042-A	44.5 (1.75)	38.10 (1.5)	34.8 (1.37)	30.48 (1.2)
60	XH2B-6042	XH2B-6042-A	50.8 (2)	44.45 (1.75)	41.1 (1.62)	36.83 (1.45)
68	XH2B-6842	XH2B-6842-A	55.9 (2.2)	49.53 (1.95)	46.2 (1.82)	41.91 (1.65)
80	XH2B-8042	XH2B-8042-A	63.5 (2.5)	57.15 (2.25)	53.8 (2.12)	49.53 (1.95)
100	XH2B-0142	XH2B-0142-A	76.2 (3)	69.85 (2.75)	66.5 (2.62)	62.23 (2.45)

General Information

■ Contact Numbers

Terminal Shape	Mated Diagram	Mounting holes (Bottom View)
Plug, straight terminals		
Plug, right-angle terminals		
Socket, straight terminals		
Socket, right-angle terminals		

- Contact numbers are not printed on the connectors. Use the triangular mark (indicates contact 1) as a guide when mounting to a board.
- On the mating side, the row terminals on the triangular mark side are called row a, and the other side is called row b. The numbers are in the order shown.
- The triangular marks on the plug and the socket should be aligned when mated. The contact numbers on both sides should match.

■ Precautions

Automated Soldering

Use tape to mask the right-angle connectors before automated soldering.

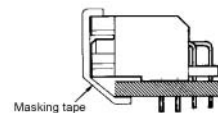



**Compact Interface Connectors
Conforming to USB Standards**

- Connect or disconnect active lines with power supplied to devices.
- High resistance to twisting force, allowing easy connection and disconnection.
- Socket model A is for personal computers and USB hubs while socket model B is for peripheral devices, such as the modem, scanner, or mouse of a personal computer.
- Cables with plugs for socket models A and B can be used to connect to personal computers and peripheral devices.

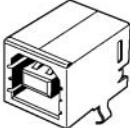

■ Socket

	Model A	Model A with 2 tiers	Model B
Shape	Right angle terminal with kink terminal XM7A-0442 	Right angle terminal with kink terminal XM7A-0442-A 	Right angle terminal with kink terminal XM7B-0442 
Part number	XM7A-0442	XM7A-0442-A	XM7B-0442
M.O.Q	30	30	30

M.O.Q: Minimum Order Quantity

■ Socket

	Model A
Shape	Cable length: 2m 
Part number	XM7Z-200AB-FC2
M.O.Q	25

M.O.Q: Minimum Order Quantity

■ Specifications

Rated Current	1A
Rated Voltage	30VAC
Contact resistance	30mΩ max. (max. 20mΩ, max 100mA) except for cable conductor resistance.
Insulation resistance	1000MΩ min. (at 500VDC)
Withstand voltage	750 VAC 1 min. (leakage current: 1mA max.)
Insertion force	max. 35N
Pulling out force	min. 10N
Insertion tolerance	1500 times
Ambient temperature	-40 to +85°C (No condensation at at low temperatures.)

■ Materials/Finish

		Socket	
		A type	B type
Housing		PBT resin with glass (UL94V-0) / black	PBT resin with glass (UL94V-1) / white
Contact	Contact	Copper-alloy/nickel spring substrate / palladium	
	Terminal	Copper-alloy / nickel plate	
Shell		Brass / tin alloy plate	

■ Dimensions

Note: All units are in millimeters unless otherwise indicated.

XM7A-0442
Model A

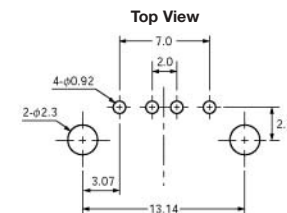
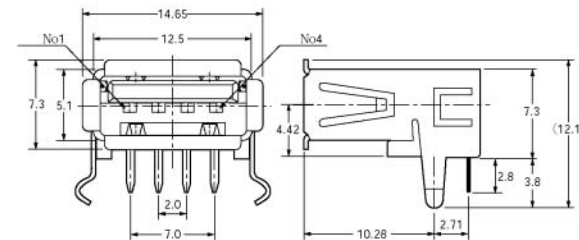

XM7A-0442-A
Model A With 2 Tiers

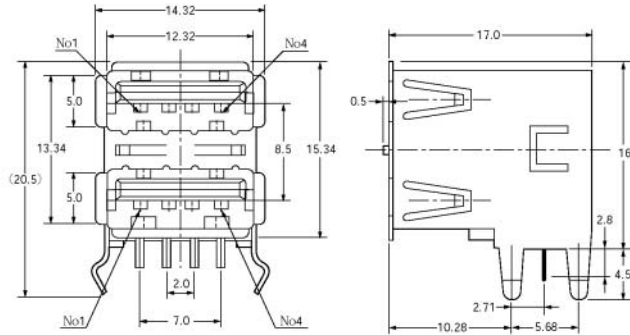

Top View

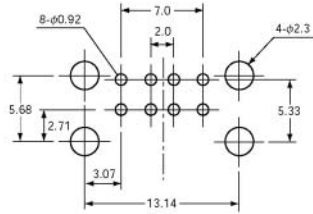

XM7B-0442
Model B

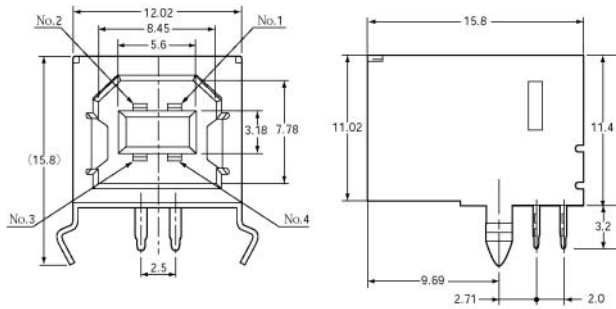
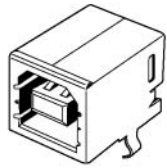

Top View

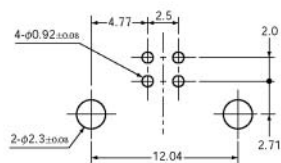

XM7Z-200AB-EC2
A -B

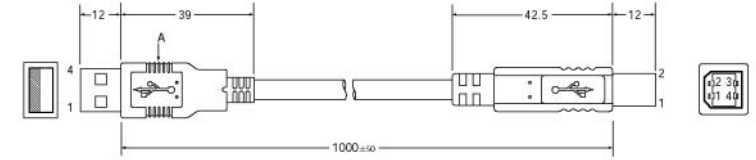

Cable length: 2m

■ Crossline

- | | |
|----|---------|
| A: | B: |
| 1 | 1 RED |
| 2 | 2 WHITE |
| 3 | 3 GREEN |
| 4 | 4 BLACK |