

# Motor Contactor J7KN

## Main contactor

- AC & DC operated
- Integrated auxiliary contacts
- Screw fixing and snap fitting (35 mm DIN-rail) up to 37 kW
- Range from 4 to 110 kW (AC 3, 380/415 V)
- Finger proof (BGV A2)
- System contactors for Fuseless Load Feeders with integrated link module

## Accessories

- front mounted single pole additional auxiliary contacts (1 NO or 1 NC)
- Side mounted additional auxiliary contacts (1 NO/1 NC)
- Mechanical interlock
- Suppressors (RC and varistor)
- Pneumatic timer modules
- Link modules MPCB - Motor contactor



## Approved Standards

| Standard     | Guide No (US,C)                              |
|--------------|--|
| UL           | NLDX, NLDX7                                  |
| ICE 947-4-1  | see Appendix on CD;<br>See "Precautions" CD. |
| VDE 0660     |  |
| EN 60947-4-1 |  |

# Ordering Information

## ■ Model Number Legend

### 1. Motor Contactors

J7KN-□-□□-□□-□□□□  
1 2 3 4 5

- 1) Motor Contactor
- 2) G: DC solenoid motor contactor
- 3) Rated Motor Current (AC3 400V)
  - 10: 10A
  - 14: 14A
  - 18: 18A
  - 22: 22A
  - 24: 24A
  - 32: 32A
  - 40: 40A
  - 50: 50A
  - 62: 62A
  - 74: 74A
  - 85: 85A
  - 110: 110A
  - 151: 150A
  - 176: 175A
  - 200: 200A
- 4) Integrated auxiliary contact
  - 10: 1NO 0NC
  - 01: 0NO 1NC
  - 21: 2NO 1NC
  - 22: 2NO 2NC
  - : 0NO 0NC
  - 4: 4 main poles
- 5) Coil voltage (AC operated)
  - 24: AC24V 50/60Hz
  - 48: AC48V 50Hz
  - 90: AC100V 50/60 Hz
  - 110: AC110V 50Hz, AC110-120V 60Hz
  - 180: AC180-210V 50Hz, AC200-240V 60Hz
  - 230: AC220-240V 50Hz, AC240V 60Hz
  - 400: AC380-415V 50Hz, AC415-440V 60Hz
  - 500: AC500-550V 50Hz, AC550-600V 60Hz

Coil voltage(DC operated)

- 24D: DC24V
- 48D: DC48V
- 110D: DC110V
- 125D: DC125V

Coil voltage(DC solenoid operated - G-type)

- 24D: DC24V
- 48D: DC48V
- 60D: DC60V
- 110D: DC110V
- 125D: DC125V
- 220D: DC200V

Coil voltage(AC & DC operated) for J7KN 151 & J7KN 176 only

- 24: 24V 50/60Hz, 24VDC
- 48: 48V 50/60Hz, 48VDC
- 110: 110-120V 50/60Hz, 110VDC
- 230: 220-240V 50/60Hz, 220VDC
- 400: 380-415V 50/60Hz

### 2. Sytem Contactors for Fuseless Load Feeders with integrated Link Module

J7KN-□□□-□□-□□□-VK3  
1 2 3 4 5

- 1) Additional reference for LVSG
- 2) Rated Motor Current (AC 3 400 V)
  - 10: 10 A
  - 14: 14 A
  - 18: 18 A
  - 22: 22 A
- 3) Integrated Auxiliary Contact
  - 10: 1NO 0NC
  - 01: 0NO 1NC
- 4) Coil voltage (AC operated)
  - 24: AC24V 50/60Hz
  - 48: AC48V 50Hz
  - 110: AC110V 50Hz, AC110-120V 60Hz
  - 180: AC180-210V 50Hz, AC200-240V 60Hz
  - 230: AC220-240V 50Hz, AC240V 60Hz
  - 400: AC380-415V 50Hz, AC415-440V 60Hz
  - 500: AC500-550V 50Hz, AC550-600V 60Hz
- 5) Attached link module VK 3

### 3. Aux. Contact Modules for Motor Contactors

J73KN-□-□□-□  
1 2 3 4

- 1) Auxiliary Contact Modules
- 2) B: for motor contactor (4-37kW)  
C: for motor contactor (11-37kW)  
D: for motor contactor (75-90kW)  
E: for motor contactor (110kW)
- 3) Combination of NO/NC contacts
  - 10: 1NO 0NC
  - 01: 0NO 1NC
  - 11: 1NO 1NC
  - 22: 2NO 2NC
- 4) S: side mounting for motor contactor (11-37kW and 75-90 kW)  
: front mounting for motor contactor (4-37kW)  
A: 6A version  
F: front mounting for motor contactor (75-90kW)  
U: EM and LB version

### 4. Accessories for Motor Contactors (Pneumatic Timers)

J74KN-□-□□ □□ □□  
1 2 3 4 5

- 1) Accessories for Motor Contactors
- 2) B: Motor Contactor (4-18.5kW)
- 3) TP: Pneumatic Timer
- 4) 40: 40 sec  
180: 180 sec
- 5) DA: ON-delayed  
IA: OFF-delayed

### 5. Accessories for Motor Contactors (Mechanical Interlock)

J74KN-□-□□  
1 2 3

- 1) Accessories for Motor Contactors
- 2) B: Motor Contactor (4-18.5kW)  
C: Motor Contactor (11-37kW)  
D: Motor Contactor (45-55kW)  
E: Motor Contactor (75-90kW)
- 3) ML: Mechanical Interlock

**6. Accessories for Motor Contactors (RC Suppressor units)**

J74KN-□-□□ □□□  
 1 2 3 4

- 1) Accessories for Motor Contactors
- 2) A: for Mini Motor Contactor and Motor Contactor (4-18.5kW) (between DIN-rail and Contactor)  
 B: for Mini Motor Contactor and Motor Contactor (4-55kW)  
 C: for Motor Contactor (4-37kW) to snap on the contactor  
 D: for Mini Motor Contactor (4-5.5kW)
- 3) RC: RC-surge suppressors
- 4) 48: 24 - 48 VAC/DC (A+B type)  
 230: 110 - 230 VAC/DC (A+B type)  
 400: 250 - 415 VAC/DC (A+B type)  
 24: 12 - 48 VAC/DC (C+D type)  
 110: 48 - 127 VAC/DC (C+D type)  
 230: 110 - 250 VAC/DC (C+D type)

**7. Accessories for Motor Contactors (4-37 kW) (Varistor units)**

J74KN-□-□□ □□□  
 1 2 3 4

- 1) Accessories for Motor Contactors
- 2) A: for Motor Contactor (4-11kW) to snap on to coil terminals  
 B: for Motor Contactor (4-37kW) to snap on to contactor
- 3) VG: Varistor Suppressors
- 4) 230: 110-230VAC/DC  
 400: 250-415VAC/DC

**8. Accessories for Motor Contactors (Additional Terminals and Terminal Covers)**

J7KN-□□□□□□□  
 1 2

- 1) Accessories for Motor Contactors
- 2) LG-9030: for Motor Contactors (22-37 kW) Additional Terminal for Single Pole  
 LG-11224: for Motor Contactors (75-90 kW) Additional Terminal for Single Pole  
 LG-10404: for Motor Contactors (75-90 kW) Terminal Cover for 3 terminals  
 Marking Systems for contactors J7KNA - J7KN 74 and aux. contact blocks J73KN-B  
 P487-1: Marking plate, 2-section without marking, divisible  
 P245-1: Marking plate, 4-section without marking, divisible

**9. Insulated wiring systems for motor contactors**

Parallel or reverse contactors  
 Star-Delta contactors

J75-WK-□□  
 1 2 3







- 1) Additional reference for LVSG
- 2) Wiring system
- 3) Combination of 2 contactors, type:  
 21 = J7KN 10 - ..22  
 41 = J7KN 24 - ..40  
  
 Star - delta combination of 3 contactors, type:  
 22 = J7KN 10 - ..22

## List of Models



### Contactors 3-pole

- Up to 210A AC3
- Up to 350A AC1
- DIN-rail mounting up to AC3 74A
- International Approvals
- Data according to IEC 947 / EN 60947









| Ratings  |                          |   |            |            |            |   |         |         |   |         |         |
|--|--------------------------|---|------------|------------|------------|---|---------|---------|---|---------|---------|
| AC3  | 400V Motor               | 10A   | 14A        | 18A        | 22A        | 24A   | 32A     | 40A     | 50A   | 62A     | 74A     |
|  | 380-400V                 | 4kW   | 5,5kW      | 7,5kW      | 11kW       | 11kW  | 15kW    | 18,5kW  | 22kW  | 30kW    | 37kW    |
|  | 660-690V                 | 5,5kW   | 7,5kW      | 10kW       | 10kW       | 15kW  | 18,5kW  | 18,5kW  | 30kW  | 37kW    | 45kW    |
| AC1  | 690V at 40°C             | 25A   | 25A        | 32A        | 32A        | 50A   | 65A     | 80A     | 110A  | 120A    | 130A    |
| Type   |                          | J7KN-10-10  | J7KN-14-10 | J7KN-18-10 | J7KN-22-10 | J7KN-24   | J7KN-32 | J7KN-40 | J7KN-50   | J7KN-62 | J7KN-74 |
| Auxiliary contacts   |                          | 1NO   | 1NO        | 1NO        | 1NO        | -   | -       | -       | -   | -       | -       |
| Type   |                          | J7KN-10-01  | J7KN-14-01 | J7KN-18-01 | J7KN-22-01 | -   | -       | -       | -   | -       | -       |
| Auxiliary contacts   |                          | 1NC   | 1NC        | 1NC        | 1NC        | -   | -       | -       | -   | -       | -       |
| Cable cross-section  |                          |   |            |            |            |   |         |         |   |         |         |
| Solid  | mm <sup>2</sup>          | 0,75 - 6  |            |            |            | 1,5 - 25  |         |         | 4 - 50  |         |         |
| Flexible   | mm <sup>2</sup>          | 1 - 4   |            |            |            | 2,5 - 16  |         |         | 10 - 35   |         |         |
| Cables per clamp   |                          | 2   |            |            |            | 1 + 1   |         |         | 1 + 1   |         |         |
| Auxiliary contact  |                          |   |            |            |            |   |         |         |   |         |         |
| I <sub>th</sub>  | 40°C                     | A 16  |            |            |            | -   |         |         | -   |         |         |
| AC15   | 230V                     | A 12  |            |            |            | -   |         |         | -   |         |         |
|  | 400V                     | A 4   |            |            |            | -   |         |         | -   |         |         |
| Power consumption of coils   |                          |   |            |            |            |   |         |         |   |         |         |
|  | Inrush VA                | 33 - 45   |            |            |            | 90 - 115  |         |         | 140 - 165   |         |         |
|  | Hold VA                  | 7 - 10  |            |            |            | 9 - 13  |         |         | 13 - 18   |         |         |
|  | Operation range of coils | 0,85 - 1,1  |            |            |            | 0,85 - 1,1  |         |         | 0,85 - 1,1  |         |         |
| Mounting   |                          | 35mm DIN-rail or base   |            |            |            |   |         |         |   |         |         |
| Additional aux. contact blocks   |                          |   |            |            |            |   |         |         |   |         |         |
| Front mounting contact configuration   |                          |  1NO |            |            |            |  1NC   |         |         |   |         |         |
|  |                          | maximal 4 J73KN-B..   |            |            |            |   |         |         |   |         |         |
| Additional aux. contact blocks   |                          |   |            |            |            |   |         |         |   |         |         |
| Side mounting contact configuration  |                          |   |            |            |            |  1NO+1NC |         |         |   |         |         |
| Overload Relay (thermal)   |                          |   |            |            |            |   |         |         |   |         |         |
| Single phase protection<br>Temperature compensation<br>Trip and alarm contacts |                          |      |            |            |            |         |         |         |  |         |         |
| Type   |                          | J7TKN-B   |            |            |            | J7TKN-C   |         |         | J7TKN-D   |         |         |
|  | Setting Ranges           |   |            |            |            |   |         |         |   |         |         |
|  | 0,12 - 0,18A             | 4 - 6A  |            |            |            | 28 - 42A  |         |         | 20 - 28A  |         |         |
|  | 0,18 - 0,27A             | 6 - 9A  |            |            |            |   |         |         | 28 - 42A  |         |         |
|  | 0,27 - 0,4A              | 8 - 11A   |            |            |            |   |         |         | 40 - 52A  |         |         |
|  | 0,4 - 0,6A               | 10 - 14A  |            |            |            |   |         |         | 52 - 65A  |         |         |
|  | 0,6 - 0,9A               | 13 - 18A  |            |            |            |   |         |         | 60 - 74A  |         |         |
|  | 0,8 - 1,2A               | 17 - 24A  |            |            |            |   |         |         |   |         |         |
|  | 1,2 - 1,8A               | 23 - 32A  |            |            |            |   |         |         |   |         |         |
|  | 1,8 - 2,7A               |   |            |            |            |   |         |         |   |         |         |
|  | 2,7 - 4A                 |   |            |            |            |   |         |         |   |         |         |



| Ratings  |                 |   |             |   |              |             |
|--|-----------------|---|-------------|---|--------------|-------------|
| AC3  | 400V Motor      | 85A   | 110A        | 150A  | 175A         | 210A        |
|  | 380-400V        | 45kW  | 55kW        | 75kW  | 90kW         | 110kW       |
| AC1  | 660-690V        | 55kW  | 55kW        | 75kW  | 110kW        | 132kW       |
|  | 690V at 40°C    | 150A  | 170A        | 230A  | 250A         | 350A        |
| Type   |                 | J7KN-85-22  | J7KN-110-22 | J7KN-151  | J7KN-176     | J7KN-200-22 |
| Auxiliary contacts   |                 | 2NO+2NC   | 2NO+2NC     | -   | -            | 2NO+2NC     |
| Type   |                 | -   | -           | -   | -            | -           |
| Auxiliary contacts   |                 | -   | -           | -   | -            | -           |
| <b>Cable cross-section</b>   |                 |   |             |   |              |             |
| Solid  | mm <sup>2</sup> | 10 - 70   | 10 - 70     | busbar  | busbar       | busbar      |
| Flexible   | mm <sup>2</sup> | 16 - 50   | 16 - 50     | 18x4  | 18x4         | 22x4        |
| Cables per clamp   |                 | 1   | 1           | 1   | 1            | 1           |
| <b>Auxiliary contact</b>   |                 |   |             |   |              |             |
| I <sub>th</sub>  | 40°C            | A 16  |             | 10  |              |             |
| AC15   | 230V            | A 12  |             | 3   |              |             |
|  | 400V            | A 6   |             | 2   |              |             |
| <b>Power consumption of coils</b>  |                 |   |             |   |              |             |
| Inrush VA  |                 | 350 - 420   |             | 350   | 350          | 1100        |
| hold VA  |                 | 23 - 29   |             | 5   | 5            | 66          |
| Operation range of coils   |                 | 0,85 - 1,1  |             | 0,85 - 1,1  |              |             |
| Mounting   |                 | base  |             |   |              |             |
| <b>Additional aux. contact blocks</b>  |                 |   |             |   |              |             |
| Front mounting contact configuration   |                 |   |             | 2NO + 2NC   | 2NO + 2NC    |             |
| <b>Additional aux. contact blocks</b>  |                 |   |             |   |              |             |
| Side mounting contact configuration  |                 |   |             | 1NO + 1NC   | 1NO + 1NC    |             |
| <b>Overload Relay (thermal)</b>  |                 |   |             |   |              |             |
| Single phase protection<br>Temperature compensation<br>Trip and alarm contacts |                 |  |             |  |              |             |
| Type   |                 | J7TKN-E   |             | J7TKN-F   |              |             |
| Setting Ranges   |                 | 60 - 90A  |             | 100 - 150A  |              |             |
|  |                 | 80 - 120A   |             | 140 - 220A  |              |             |
|  |                 |   |             |   |              |             |
| <b>Busbar Sets</b>   |                 |   |             |   |              |             |
|  |                 |   |             | J74TK-SU-176  | J74TK-SU-200 |             |
|  |                 |   |             |   |              |             |
|  |                 |   |             |   |              |             |
|  |                 |   |             |   |              |             |

Low voltage switch gear

**Contactors 3-pole**  
**AC Operated**

|   | Ratings                    |            |                    | Rated Current<br>AC1<br>690V<br>A | Aux. Contacts |    | Type  | Pack   | Weight |  |
|---|----------------------------|------------|--------------------|-----------------------------------|---------------|----|---|--|--------|--|
|   | AC2, AC3                   |            |                    |                                   | Built-in      |    |   |  |        | Additional<br>see<br>page I-33<br>Type |
|   | 380V<br>400V<br>415V<br>kW | 500V<br>kW | 660V<br>690V<br>kW |                                   | NO            | NC |   |  |        |  |
|    | 4                          | 5.5        | 5.5                | 25                                | 1             | -  | max. 4<br>J73KN-B   | Coil Voltage <sup>1</sup><br>24V 50/60Hz<br>110V 50Hz<br>220-240V 50Hz | pcs.   | kg/pc.                                 |
|   | 4                          | 5.5        | 5.5                | 25                                | -             | 1  |   |  |        |  |
|   | 5.5                        | 7.5        | 7.5                | 25                                | 1             | -  |   |  |        |  |
|   | 5.5                        | 7.5        | 7.5                | 25                                | -             | 1  |   |  |        |  |
|   | 7.5                        | 10         | 10                 | 32                                | 1             | -  |   |  |        |  |
|   | 7.5                        | 10         | 10                 | 32                                | -             | 1  |   |  |        |  |
|   | 11                         | 10         | 10                 | 32                                | 1             | -  |   |  |        |  |
| 11  | 10                         | 10         | 32                 | -                                 | 1             |    |   |  |        |  |
| J7KN-10-10□□□   | 1                          | 0.23       |                    |                                   |               |    |   |  |        |  |
| J7KN-10-01□□□   | 1                          | 0.23       |                    |                                   |               |    |   |  |        |  |
| J7KN-14-10□□□   | 1                          | 0.23       |                    |                                   |               |    |   |  |        |  |
| J7KN-14-01□□□   | 1                          | 0.23       |                    |                                   |               |    |   |  |        |  |
| J7KN-18-10□□□   | 1                          | 0.23       |                    |                                   |               |    |   |  |        |  |
| J7KN-18-01□□□   | 1                          | 0.23       |                    |                                   |               |    |   |  |        |  |
| J7KN-22-10□□□   | 1                          | 0.23       |                    |                                   |               |    |   |  |        |  |
| J7KN-22-01□□□   | 1                          | 0.23       |                    |                                   |               |    |   |  |        |  |
|    | 4                          | 5.5        | 5.5                | 25                                | -             | -  | -   | -  | -      | -                                      |
|   | 4                          | 5.5        | 5.5                | 25                                | -             | -  |   |  |        |  |
|   | 5.5                        | 7.5        | 7.5                | 25                                | -             | -  |   |  |        |  |
|   | 5.5                        | 7.5        | 7.5                | 25                                | -             | -  |   |  |        |  |
|   | 7.5                        | 10         | 10                 | 32                                | -             | -  |   |  |        |  |
|   | 7.5                        | 10         | 10                 | 32                                | -             | -  |   |  |        |  |
|   | 11                         | 10         | 10                 | 32                                | -             | -  |   |  |        |  |
| 11  | 10                         | 10         | 32                 | -                                 | -             |    |   |  |        |  |
|   | 11                         | 15         | 15                 | 50                                | -             | -  | max. 4<br>J73KN-B +<br>2 J73KN-<br>C-11S  | Coil Voltage <sup>1</sup><br>220-230V 50Hz<br>380-400V 50Hz            | pcs.   | kg/pc.                                 |
|   | 15                         | 18.5       | 18.5               | 65                                | -             | -  |   |  |        |  |
|   | 18.5                       | 18.5       | 18.5               | 80                                | -             | -  |   |  |        |  |
| J7KN-24□□□  | 1                          | 0.48       |                    |                                   |               |    |   |  |        |  |
| J7KN-32□□□  | 1                          | 0.48       |                    |                                   |               |    |   |  |        |  |
| J7KN-40□□□  | 1                          | 0.48       |                    |                                   |               |    |   |  |        |  |
|  | 22                         | 30         | 30                 | 110                               | -             | -  | max. 4<br>J73KN-B +<br>2 J73KN-<br>C11S   | Coil Voltage <sup>1</sup><br>220-230V 50Hz<br>380-400V 50Hz            | pcs.   | kg/pc.                                 |
|   | 30                         | 37         | 37                 | 120                               | -             | -  |   |  |        |  |
|   | 37                         | 45         | 45                 | 130                               | -             | -  |   |  |        |  |
| J7KN-50□□□  | 1                          | 0.85       |                    |                                   |               |    |   |  |        |  |
| J7KN-62□□□  | 1                          | 0.85       |                    |                                   |               |    |   |  |        |  |
| J7KN-74□□□  | 1                          | 0.85       |                    |                                   |               |    |   |  |        |  |
|   | Ratings                    |            |                    | Rated Current<br>AC1<br>690V<br>A | Aux. Contacts |    | Type  | Pack   | Weight |  |
|   | AC2, AC3                   |            |                    |                                   | Built-in      |    |   |  |        |  |
|   | 380V<br>415V<br>kW         | 500V<br>kW | 660V<br>690V<br>kW |                                   | NO            | NC |   |  |        |  |
|  | 45                         | 55         | 55                 | 150                               | 2             | 2  |   | Coil Voltage <sup>1</sup><br>220-230V 50Hz<br>380-400V 50Hz            | pcs.   | kg/pc.                                 |
|   | 55                         | 75         | 55                 | 170                               | 2             | 2  |   |  |        |  |
| J7KN-85-22□□□   | 1                          | 1.8        |                    |                                   |               |    |   |  |        |  |
| J7KN-110-22□□□  | 1                          | 1.9        |                    |                                   |               |    |   |  |        |  |
|  | 75                         | 75         | 75                 | 230                               | -             | -  | max. 3<br>1 x J73KN-<br>D22F or<br>1 x J73KN-<br>D11F and<br>2 x J73KN-<br>D11S | Coil Voltage <sup>1</sup><br>220-230V 50Hz<br>380-400V 50Hz            | pcs.   | kg/pc.                                 |
|   | 90                         | 90         | 90                 | 250                               | -             | -  |   |  |        |  |
| J7KN-151□□□ <sup>*2</sup>   | 1                          | 4          |                    |                                   |               |    |   |  |        |  |
| J7KN-176□□□ <sup>*2</sup>   | 1                          | 4          |                    |                                   |               |    |   |  |        |  |
|  | 110                        | 132        | 132                | 350                               | 2             | 2  |   | Coil Voltage <sup>1</sup><br>220-230V 50Hz<br>380-400V 50Hz            | 1      | 7.3                                    |
| J7KN-200-22□□□  | 1                          | 7.3        |                    |                                   |               |    |   |  |        |  |

<sup>\*1</sup> Coil voltage range and other coil voltages see page I-36

<sup>\*2</sup> AC and DC in one coil

**Contactors 3-pole**  
**DC Operated**

| Aux. Contacts<br>see page I-33 |    | Type  | Coil voltage              |         | Weight<br>kg/pc. | Accept Overload<br>Relay<br>page I-56 | Busbar Set for<br>Overload Relay<br>page I-57 | Wiring Diagram<br><br>Coil Circuits see page I-35 |
|--------------------------------|----|---|---------------------------|---------|------------------|---------------------------------------|---|---|
| Built-in                       |    |   | 24                        | 24V DC  |                  |                                       |   |   |
| NO                             | NC | Type  | 48                        | 48V DC  | Type             | Type                                  | Terminal Markings                             |   |
| 1                              | -  | max. 3<br>J73KN-B*1   | J7KN-10-10□□□D            | 24V DC  | 0.25             | J7TKN-B                               | -   | -10   |
| -                              | 1  |   | J7KN-10-01□□□D            | 48V DC  | 0.25             |                                       |   | -   |
| 1                              | -  |   | J7KN-14-10□□□D            | 60V DC  | 0.25             |                                       |   | -   |
| -                              | 1  |   | J7KN-14-01□□□D            | 110V DC | 0.25             |                                       |   | -   |
| 1                              | -  |   | J7KN-18-10□□□D            | 125V DC | 0.25             |                                       |   | -   |
| -                              | 1  |   | J7KN-18-01□□□D            | 220V DC | 0.25             |                                       |   | -   |
| 1                              | -  |   | J7KN-22-10□□□D            |         | 0.25             |                                       |   | -   |
| -                              | 1  | J7KN-22-01□□□D  |                           | 0.25    |                  |                                       | -   |   |
| 1                              | -  | max. 4<br>J73KN-B   | J7KNG-10-10□□□D           | 24V DC  | 0.53             | J7TKN-B                               | -   | -10   |
| -                              | 1  |   | J7KNG-10-01□□□D           | 48V DC  | 0.53             |                                       |   | -   |
| 1                              | -  |   | J7KNG-14-10□□□D           | 60V DC  | 0.53             |                                       |   | -   |
| -                              | 1  |   | J7KNG-14-01□□□D           | 110V DC | 0.53             |                                       |   | -   |
| 1                              | -  |   | J7KNG-18-10□□□D           | 125V DC | 0.53             |                                       |   | -   |
| -                              | 1  |   | J7KNG-18-01□□□D           | 220V DC | 0.53             |                                       |   | -   |
| 1                              | -  |   | J7KNG-22-10□□□D           |         | 0.53             |                                       |   | -   |
| -                              | 1  | J7KNG-22-01□□□D   |                           | 0.53    |                  |                                       | -   |   |
| -                              | -  | max. 3<br>J73KN-B*1<br>+<br>2 J73KN-C-11S                         | J7KN-24□□□D               | 24V DC  | 0.55             | J7TKN-B                               | -   | -00   |
| -                              | -  |   | J7KN-32□□□D               | 48V DC  | 0.55             | J7TKN-C                               | -   | -   |
| -                              | -  |   | J7KN-40□□□D               | 60V DC  | 0.55             |                                       |   | -   |
| -                              | -  | max. 3<br>J73KN-B*1<br>+<br>2 J73KN-C-11S                         | J7KN-50□□□D               | 110V DC | 0.9              | J7TKN-D                               | -   | -00   |
| -                              | -  |   | J7KN-62□□□D               | 125V DC | 0.9              |                                       |   | -   |
| -                              | -  |   | J7KN-74□□□D               | 220V DC | 0.9              |                                       |   | -   |
| Aux. Contacts                  |    | Type  | Coil voltage              |         | Weight<br>kg/pc. | Accept Overload<br>Relay<br>page I-56 | Busbar Set for<br>Overload Relay<br>page I-57 |   |
| Built-in                       |    |   | 110                       | 110V DC |                  |                                       |   |   |
| NO                             | NC | Type  | 220                       | 220V DC | Type             | Type                                  |   |   |
| 2                              | 1  |   | J7KN-85-21□□□D            | 110V DC | 1.8              | J7TKN-E                               |   | -21/-22   |
| 2                              | 1  |   | J7KN-110-21□□□D           | 220V DC | 1.9              |                                       |   | -   |
| -                              | -  | max. 3<br>1 x J73KN-D22 or<br>1 x J73KN-D11 and<br>2 x J73KN-D11S | J7KN-151-□□□ <sup>2</sup> | 110V DC | 4                | J7TKN-F                               | J73TK-SU-176                                  | -00   |
| -                              | -  |   | J7KN-176-□□□ <sup>2</sup> | 220V DC | 4                | J7TKN-F                               |   | -   |
| 2                              | 1  |   | J7KN-200-21□□□D           | 110V DC | 7.3              | J7TKN-F                               | J73TK-SU-200                                  | -21/-22   |

\*1 Only 3 additional Aux. Contacts are possible! (See also the wiring diagrams coil circuit DC operated page I-35)

\*2 AC and DC in one coil

Low voltage  
switch gear

**System Contactors for Fuseless Load Feeders with integrated Link Module** (see page I-72)



**AC Operated**

|   | Ratings                                |            |                    | Rated Current<br>AC1<br>690V<br>A | Aux. Contacts |                                | Type              | Pack  | Weight           |                              |  |
|---|--|------------|--------------------|-----------------------------------|---------------|--------------------------------|-------------------|---|------------------|------------------------------|--|
|   | AC2, AC3<br>380V<br>400V<br>415V<br>kW | 500V<br>kW | 660V<br>690V<br>kW |                                   | Built-in      | Additional<br>see<br>page I-33 |                   |   |                  |                              |  |
|   |  |            |                    |                                   | NO            | NC                             | Type              | pcs.  | kg/pc.           |                              |  |
|  | 4                                      | 5.5        | 5.5                | 25                                | 1             | -                              | max. 4<br>J73KN-B | Coil Voltage <sup>*1</sup><br>24V 50/60Hz<br>110V 50Hz<br>220-240V 50Hz | 1<br>1<br>1<br>1 | 0.25<br>0.25<br>0.25<br>0.25 |  |
|   | 5.5                                    | 7.5        | 7.5                | 25                                | 1             | -                              |                   |   |                  |                              | <b>J7KN-10-10 □□□-VK3</b>                              |
|   | 7.5                                    | 10         | 10                 | 32                                | 1             | -                              |                   |   |                  |                              | <b>J7KN-14-10 □□□-VK3</b>                              |
|   | 11                                     | 10         | 10                 | 32                                | 1             | -                              |                   |   |                  |                              | <b>J7KN-18-10 □□□-VK3</b><br><b>J7KN-22-10 □□□-VK3</b> |

<sup>\*1</sup> Coil voltage range and other coil voltages see page I-36

**Contactors 4-pole**

**AC Operated**

|   | Ratings                                   |                   | Rated Current<br>AC1<br>690V<br>A | Aux. Contacts<br>see page I-33 |                            | Type  | Pack  | Weight           |                              |  |
|---|---|-------------------|-----------------------------------|--------------------------------|----------------------------|---|---|------------------|------------------------------|--|
|   | AC2,<br>AC3<br>380V<br>400V<br>415V<br>kW | AC1<br>400V<br>kW |                                   | Built-in                       | Additional<br>see<br>below |   |   |                  |                              |  |
|   |   |                   |                                   | NO                             | NC                         | Type  | pcs.  | kg/pc.           |                              |  |
|  | 4   | 17.5              | 25                                | -                              | -                          | max. 4<br>J73KN-B                                   | Coil Voltage <sup>*1</sup><br>24V 50/60Hz<br>110V 50Hz<br>220-240V 50Hz | 1<br>1<br>1<br>1 | 0.22<br>0.22<br>0.22<br>0.22 |  |
|   | 5.5                                       | 17.5              | 25                                | -                              | -                          |   |   |                  |                              | <b>J7KN-10-4 □□□</b>                           |
|   | 7.5                                       | 22                | 32                                | -                              | -                          |   |   |                  |                              | <b>J7KN-14-4 □□□</b>                           |
|   | 11  | 22                | 32                                | -                              | -                          |   |   |                  |                              | <b>J7KN-18-4 □□□</b><br><b>J7KN-22-4 □□□</b>   |
|  | 75  | 159               | 230                               | -                              | -                          | max. 3<br>J73KN-D-11F<br>J73KN-D-22F<br>J73KN-D-11S | Coil Voltage <sup>*1</sup><br>24V 50/60Hz<br>110V 50Hz<br>220-240V 50Hz | 1<br>1           | 4.7<br>4.7                   |  |
|   | 90  | 173               | 250                               | -                              | -                          |   |   |                  |                              | <b>J7KN-151-4 □□□</b><br><b>J7KN-176-4 □□□</b> |

<sup>\*1</sup> Coil voltage range and other coil voltages see page I-36

**DC Operated**

|   | Ratings                                   |                   | Rated Current<br>AC1<br>690V<br>A | Aux. Contacts<br>see page I-33 |                            | Type              | Pack  | Weight           |                  |  |
|---|---|-------------------|-----------------------------------|--------------------------------|----------------------------|-------------------|---|------------------|------------------|--|
|   | AC2,<br>AC3<br>380V<br>400V<br>415V<br>kW | AC1<br>400V<br>kW |                                   | Built-in                       | Additional<br>see<br>below |                   |   |                  |                  |  |
|   |   |                   |                                   | NO                             | NC                         | Type              | pcs.  | kg/pc.           |                  |  |
|  | 4   | 17.5              | 25                                | -                              | -                          | max. 4<br>J73KN-B | Coil Voltage <sup>*1</sup><br>24V 50/60Hz<br>110V 50Hz<br>220-240V 50Hz | 1<br>1<br>1<br>1 | -<br>-<br>-<br>- |  |
|   | 5.5                                       | 17.5              | 25                                | -                              | -                          |                   |   |                  |                  | <b>J7KNG-10-4 □□□D</b>                           |
|   | 7.5                                       | 22                | 32                                | -                              | -                          |                   |   |                  |                  | <b>J7KNG-14-4 □□□D</b>                           |
|   | 11  | 22                | 32                                | -                              | -                          |                   |   |                  |                  | <b>J7KNG-18-4 □□□D</b><br><b>J7KNG-22-4 □□□D</b> |



<sup>\*1</sup> Coil voltage range and other coil voltages see page I-36



**Auxiliary Contact Blocks for contactors J7KN-10... to -74... type J73KN for low level switching\*1**

| Front mounting  | Rated Operational Current |              |             | Contacts |    |    |    | Type               | Pack | Weight |
|---|---------------------------|--------------|-------------|----------|----|----|----|--------------------|------|--------|
|   | AC15<br>230V              | AC15<br>400V | AC1<br>690V | NO       | NC | EM | LB |                    |      |        |
|  | A                         | A            | A           |          |    |    |    |                    | pcs. | kg/pc. |
|   | 3                         | 2            | 10          | 1        | -  | -  | -  | <b>J73KN-B-10</b>  | 10   | 0.02   |
|   | 3                         | 2            | 10          | -        | 1  | -  | -  | <b>J73KN-B-01</b>  | 10   | 0.02   |
|   | 3                         | 2            | 10          | -        | -  | 1  | -  | <b>J73KN-B-10U</b> | 10   | 0.02   |
|   | 3                         | 2            | 10          | -        | -  | -  | 1  | <b>J73KN-B-01U</b> | 10   | 0.02   |
|   | 6                         | 4            | 25          | 1        | -  | -  | -  | <b>J73KN-B-10A</b> | 10   | 0.02   |
|   | 6                         | 4            | 25          | -        | 1  | -  | -  | <b>J73KN-B-01A</b> | 10   | 0.02   |

**Auxiliary Contact Blocks for contactors J7KN-151... to 176... type J73KN for low level switching**

|  | Rated Operational Current |              |             | Mounting | Contacts |    | Type               | Pack | Weight |
|--|---------------------------|--------------|-------------|----------|----------|----|--------------------|------|--------|
|  | AC15<br>230V              | AC15<br>400V | AC1<br>690V |          | NO       | NC |                    |      |        |
|   | A                         | A            | A           | front    |          |    |                    | pcs. | kg/pc. |
|  | 3                         | 2            | 10          |          | 1        | 1  | <b>J73KN-D-11F</b> | 1    | 0.08   |
|  | 3                         | 2            | 10          |          | 2        | 2  | <b>J73KN-D-22F</b> | 1    | 0.08   |
|  | 3                         | 2            | 10          | side     | 1        | 1  | <b>J73KN-D-11S</b> | 1    | 0.12   |

**Auxiliary Contact Blocks for contactors J7KN-24... to KN-110 and J7KN-200... type J73KN for low level switching**

|   | Rated Operational Current |              |             | Mounting                             | Contacts |    | Type               | Pack | Weight |
|---|---------------------------|--------------|-------------|--------------------------------------|----------|----|--------------------|------|--------|
|   | AC15<br>230V              | AC15<br>400V | AC1<br>690V |                                      | NO       | NC |                    |      |        |
|  | A                         | A            | A           |                                      |          |    |                    | pcs. | kg/pc. |
|   | 3                         | 2            | 10          | max. 2 side mounting<br>(J7KN-24-74) | 1        | 1  | <b>J73KN-C-11S</b> | 10   | 0.02   |
|   | 3                         | 2            | 10          | max. 2 front mounting<br>(J7KN-200)  | 2        | 2  | <b>J73KN-E-22</b>  | 1    | 0.12   |

Low voltage switch gear

**Pneumatic Timer for contactors J7KN-10... to -40...**







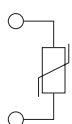

|   | Function  | Time range<br>s | Contacts |    |    |    | Type                   | Pack | Weight |
|---|-----------|-----------------|----------|----|----|----|------------------------|------|--------|
|   |           |                 | NO       | NC | NO | NC |                        |      |        |
|  | On-delay  | 0.1 - 40        | 1        | 1  | -  | -  | <b>J74KN-B-TP40DA</b>  | 1    | 0.09   |
|   | On-delay  | 10 - 180        | 1        | 1  | -  | -  | <b>J74KN-B-TP180DA</b> | 1    | 0.09   |
|   | Off-delay | 0.1 - 40        | -        | -  | 1  | 1  | <b>J74KN-B-TP40IA</b>  | 1    | 0.09   |
|   | Off-delay | 10 - 180        | -        | -  | 1  | 1  | <b>J74KN-B-TP180IA</b> | 1    | 0.09   |

**Mechanical Interlocks**

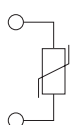
|   | Interlocks contactor with contactor |                     | Mounting   | Type              | Pack | Weight |
|---|-------------------------------------|---------------------|------------|-------------------|------|--------|
|   | Type                                | Type                |            |                   |      |        |
|  | J7KN10 - J7KN40                     | + J7KN10 - J7KN40   | horizontal | <b>J74KN-B-ML</b> | 1    | 0.006  |
|   | J7KN24 - J7KN74                     | + J7KN24 - J7KN74   | horizontal | <b>J74KN-C-ML</b> | 1    | 0.010  |
|   | J7KN85 - J7KN110                    | + J7KN85 - J7KN110  | horizontal | <b>J74KN-D-ML</b> | 1    | 0.076  |
|   | J7KN151 - J7KN176                   | + J7KN151 - J7KN176 | horizontal | <b>J74KN-E-ML</b> | 1    | 0.076  |

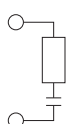
1. suitable according to DIN 19240 (test ratings 17V DC, 5mA) Technical data see page I-49

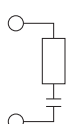
## Suppressor Units

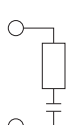
|  |  | Suitable for Contactors | Suitable for Coil Voltages              |                         | Type  | Pack pcs.      | Weight kg/pc.          |
|--|--|-------------------------|---|-------------------------|---|----------------|------------------------|
|   |   | J7KNA<br>J7KN10-J7KN22  | 110 - 230 V<br>250 - 415 V              | AC/DC<br>AC/DC          | <b>J74KN-A-VG230</b><br><b>J74KN-A-VG400</b>                        | 10<br>10       | 0.01<br>0.01           |
|   |   | J7KN10-J7KN74           | 110 - 230 V<br>250 - 415 V              | AC/DC<br>AC/DC          | <b>J74KN-B-VG230</b><br><b>J74KN-B-VG400</b>                        | 10<br>10       | 0.02<br>0.02           |
|   |   | J7KNA                   | 12 - 48 V<br>48 - 127 V<br>110 - 230 V  | AC/DC<br>AC/DC<br>AC/DC | <b>J74KN-D-RC24</b><br><b>J74KN-D-RC110</b><br><b>J74KN-D-RC230</b> | 10<br>10<br>10 | 0.02<br>0.036<br>0.036 |
|    |   | J7KN10-J7KN74           | 12 - 48 V<br>48 - 127 V<br>110 - 230 V  | AC/DC<br>AC/DC<br>AC/DC | <b>J74KN-C-RC24</b><br><b>J74KN-C-RC110</b><br><b>J74KN-C-RC230</b> | 10<br>10<br>10 | 0.02<br>0.036<br>0.036 |
|  |  | J7KN85-J7KN110          | 12 - 24 V<br>110 - 250 V<br>250 - 415 V | AC/DC<br>AC/DC<br>AC/DC | <b>J74KN-B-RC48</b><br><b>J74KN-B-RC230</b><br><b>J74KN-B-RC400</b> | 5<br>5<br>5    | 0.04<br>0.04<br>0.04   |

## Additional Terminals Single Pole

|   | For Contactors                   | Cable Cross-sections to clamp mm <sup>2</sup> |               |                                 | Type  | Pack pcs. | Weight kg/pc. |
|---|----------------------------------|---|---------------|---------------------------------|---|-----------|---------------|
|   |                                  | solid or stranded                             | flexible      | flex. with multi-core cable end |   |           |               |
|  | J7KN50 - KN74<br>J7KN151 - KN176 | 4 - 35<br>16 - 120                            | 6 - 25<br>--- | 4 - 25<br>16 - 95               | <b>J74KN-LG-9030</b><br><b>J74KN-LG-11224</b> | 1         | 0.052         |



## Terminal Covers for terminal protection according DIN 57106, BVG-A2

|   | For Contactors  | Specification | Type                  | Pack pcs. | Weight kg/pc. |
|---|-----------------|---------------|-----------------------|-----------|---------------|
|  | J7KN151 - KN176 | one unit      | <b>J74KN-LG-10404</b> | 1         | 0.12          |

## Marking Systems for contactors J7KNA to J7KN74 and aux. contact blocks J73KN-B

|   | Description   | Specification                        | Type                | Pack pcs. | Weight kg/pc. |
|---|---------------|--------------------------------------|---------------------|-----------|---------------|
|  | Marking Plate | 2-section without marking, divisible | <b>J74KN-P487-1</b> | 100       | 0.025         |
|   | Marking Plate | 4-section without marking, divisible | <b>J74KN-P245-1</b> | 100       | 0.050         |

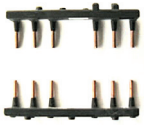
Insulated wiring systems for motor contactors

|   | Description                                      | Version (A) | For contactors | Type             | Pack pcs |
|---|--|-------------|----------------|------------------|----------|
|  | For reversing or parallel contactors ( 2 parts ) | 25          | J7KN 10 - 22   | <b>J75-WK-21</b> | 1        |
|   |  | 40          | J7KN 24 - 40   | <b>J75-WK-41</b> | 1        |
|  | For star-delta combination (3 parts)             | 25          | J7KN 10 - 22   | <b>J75-WK-22</b> | 1        |

■ Wiring Diagrams Coil Circuit

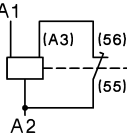
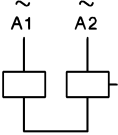
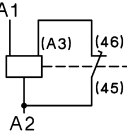
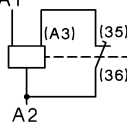
| AC operated  | DC operated with double winding coil*1  |
|--|---|
| J7KN-10... to J7KN-110...<br> | J7KN-10...D to J7KN-22...D<br> |
| J7KN-200...<br>               | J7KN-24...D to J7KN-74...D<br> |
|  | J7KN-110...D<br>             |

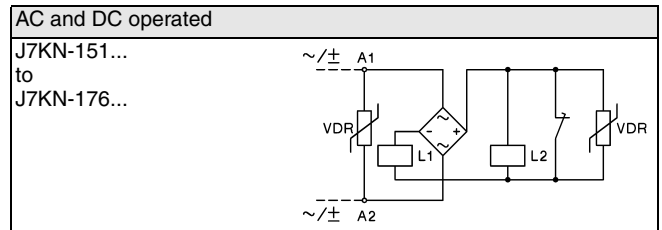

\*1) Only 3 additional Aux. Contacts are possible!  
(See also page I-31)

# Specifications

## ■ Coil Voltages

Type-suffix for contactor types J7KN-10... to J7KN-74...

| Suffix to contactor type e.g.<br><b>J7KN-10-10-24</b> | Voltage Marking at the coil |                | Rated Control Voltage U <sub>s</sub> range for |            |            |            |
|---|-----------------------------|----------------|--|------------|------------|------------|
|   | for 50Hz V                  | for 60Hz V     | 50Hz   |            | 60Hz       |            |
|   |                             |                | min V  | max V      | min V      | max V      |
| <b>24</b>   | <b>24</b>                   | <b>24</b>      | <b>22</b>                                      | <b>24</b>  | <b>24</b>  | <b>27</b>  |
| 48  | 48                          | 48             | 44   | 48         | 48         | 52         |
| <b>110</b>  | <b>110</b>                  | <b>110-120</b> | <b>100</b>                                     | <b>110</b> | <b>110</b> | <b>122</b> |
| 180   | 180-210                     | 200-240        | 180  | 210        | 200        | 240        |
| <b>230</b>  | <b>220-240</b>              | <b>240</b>     | <b>220</b>                                     | <b>240</b> | <b>240</b> | <b>264</b> |
| <b>400</b>  | <b>380-415</b>              | <b>415-440</b> | <b>380</b>                                     | <b>415</b> | <b>415</b> | <b>460</b> |
| 500   | 500-550                     | 550-600        | 500  | 550        | 550        | 600        |

Standard voltages in bold type letter

Type-suffix for contactor types J7KN-85... to J7KN-110...

| Suffix to contactor type e.g.<br><b>J7KN-85-22-24</b> | Voltage Marking at the coil |                | Rated Control Voltage U <sub>s</sub> range for |            |            |            |
|---|-----------------------------|----------------|--|------------|------------|------------|
|   | for 50Hz V                  | for 60Hz V     | 50Hz   |            | 60Hz       |            |
|   |                             |                | min V  | max V      | min V      | max V      |
| <b>20</b>   | <b>20</b>                   | <b>24</b>      | <b>20</b>                                      | <b>22</b>  | <b>24</b>  | <b>26</b>  |
| <b>24</b>   | <b>24</b>                   |                | <b>24</b>                                      | <b>27</b>  | <b>29</b>  | <b>32</b>  |
| 48  | 48                          | 60             | 47   | 52         | 56         | 62         |
| 90  | 90                          | 110-120        | 90   | 100        | 108        | 120        |
| <b>110</b>  | <b>110-120</b>              |                | <b>110</b>                                     | <b>122</b> | <b>132</b> | <b>146</b> |
| 180   | 180-200                     | 208-240        | 180  | 200        | 208        | 240        |
| <b>230</b>  | <b>220-240</b>              | <b>277</b>     | <b>220</b>                                     | <b>240</b> | <b>264</b> | <b>288</b> |
| <b>400</b>  | <b>380-415</b>              | <b>460-480</b> | <b>380</b>                                     | <b>415</b> | <b>455</b> | <b>498</b> |
| 500   | 500-550                     | 600-660        | 500  | 550        | 600        | 660        |

Standard voltages in bold type letter

Type-suffix for contactor types J7KN-151... to J7KN-200...

| Suffix to contactor type e.g.<br><b>J7KN-151-230</b> | Voltage Marking at the coil |             | Rated Control Voltage U <sub>s</sub> range for |            |            |            |
|--|-----------------------------|-------------|--|------------|------------|------------|
|  | for 50 Hz V                 | for 60 Hz V | 50Hz   |            | 60Hz       |            |
|  |                             |             | min V  | max V      | min V      | max V      |
| 24   | 24                          |             | 24   | 24         | -          | -          |
| 48   | 48                          |             | 48   | 48         | -          | -          |
| 110  | 110                         | 110         | 110  | 110        | 110        | 110        |
| <b>230</b>   | <b>220-230</b>              | <b>220</b>  | <b>220</b>                                     | <b>230</b> | <b>220</b> | <b>220</b> |
| <b>400</b>   | <b>380-400</b>              |             | <b>380</b>                                     | <b>400</b> | -          | -          |

Standard voltages in bold type letter

## ■ Engineering data and characteristics

### Approximate Values for three-phase Motors

#### Motor Full Load Currents

Approximate values of motor F.L.C. and minimum „slow blow“ respectively „gL“ short-circuit fuse

| Motor rating<br>Range according to BS for 415V |       |     |      |    | 220-230V Motor<br>Value of fusing at motor start |             |         | 240V Motor<br>Value of fusing at motor start |             |         | 380-400V Motor<br>Value of fusing at motor start |             |         | 415V Motor<br>Value of fusing at motor start |             |         | 500V Motor<br>Value of fusing at motor start |             |         | 660-690V Motor<br>Value of fusing at motor start |             |         |
|--|-------|-----|------|----|--|-------------|---------|--|-------------|---------|--|-------------|---------|--|-------------|---------|--|-------------|---------|--|-------------|---------|
| kW   | PS-hp | hp  | cos  | %  | F.L.C.<br>A                                      | D.O.L.<br>A | YD<br>A | F.L.C.<br>A                                  | D.O.L.<br>A | YD<br>A | F.L.C.<br>A                                      | D.O.L.<br>A | YD<br>A | F.L.C.<br>A                                  | D.O.L.<br>A | YD<br>A | F.L.C.<br>A                                  | D.O.L.<br>A | YD<br>A | F.L.C.<br>A                                      | D.O.L.<br>A | YD<br>A |
| 0.06   | 0.08  | -   | 0.7  | 59 | 0.38   | 1           | 1       | 0.35   | 1           | 1       | 0.22   | 1           | 1       | -  | -           | -       | 0.16   | 1           | 1       | -  | -           | -       |
| 0.09   | 0.12  | -   | 0.7  | 60 | 0.55   | 2           | 2       | 0.5  | 2           | 2       | 0.33   | 1           | 1       | -  | -           | -       | 0.24   | 1           | 1       | -  | -           | -       |
| 0.12   | 0.16  | -   | 0.7  | 61 | 0.76   | 2           | 2       | 0.68   | 2           | 2       | 0.42   | 2           | 2       | -  | -           | -       | 0.33   | 1           | 1       | -  | -           | -       |
| 0.18   | 0.24  | -   | 0.7  | 61 | 1.1  | 2           | 2       | 1  | 2           | 2       | 0.64   | 2           | 2       | -  | -           | -       | 0.46   | 1           | 1       | -  | -           | -       |
| 0.25   | 0.34  | -   | 0.7  | 62 | 1.4  | 4           | 2       | 1.38   | 4           | 2       | 0.88   | 2           | 2       | -  | -           | -       | 0.59   | 2           | 2       | -  | -           | -       |
| 0.37   | 0.5   | -   | 0.72 | 64 | 2.1  | 4           | 4       | 1.93   | 4           | 4       | 1.22   | 4           | 2       | -  | -           | -       | 0.85   | 2           | 2       | 0.7  | 2           | 2       |
| 0.55   | 0.75  | -   | 0.75 | 69 | 2.7  | 4           | 4       | 2.3  | 4           | 4       | 1.5  | 4           | 2       | -  | -           | -       | 1.2  | 4           | 2       | 0.9  | 2           | 2       |
| 0.75   | 1     | 1   | 0.8  | 74 | 3.3  | 6           | 4       | 3.1  | 6           | 4       | 2  | 4           | 4       | 2  | 4           | 4       | 1.48   | 4           | 2       | 1.1  | 2           | 2       |
| 1.1  | 1.5   | 1.5 | 0.83 | 77 | 4.9  | 10          | 6       | 4.1  | 6           | 6       | 2.6  | 4           | 4       | 2.5  | 4           | 4       | 2.1  | 4           | 4       | 1.5  | 4           | 2       |
| 1.5  | 2     | 2   | 0.83 | 78 | 6.2  | 10          | 10      | 5.6  | 10          | 10      | 3.5  | 6           | 4       | 3.5  | 6           | 4       | 2.6  | 4           | 4       | 2  | 4           | 4       |
| 2.2  | 3     | 3   | 0.83 | 81 | 8.7  | 16          | 10      | 7.9  | 16          | 10      | 5  | 10          | 6       | 5  | 10          | 6       | 3.8  | 6           | 6       | 2.9  | 6           | 4       |
| 2.5  | 3.4   | -   | 0.83 | 81 | 9.8  | 16          | 16      | 8.9  | 16          | 10      | 5.7  | 10          | 10      | -  | -           | -       | 4.3  | 6           | 6       | -  | -           | -       |
| 3  | 4     | 4   | 0.84 | 81 | 11.6   | 20          | 16      | 10.6   | 20          | 16      | 6.6  | 16          | 10      | 6.5  | 16          | 10      | 5.1  | 10          | 10      | 3.5  | 6           | 4       |
| 3.7  | 5     | 5   | 0.84 | 82 | 14.2   | 25          | 20      | 13   | 25          | 16      | 8.2  | 16          | 10      | 7.5  | 16          | 10      | 6.2  | 16          | 10      | -  | -           | -       |
| 4  | 5.5   | -   | 0.84 | 82 | 15.3   | 25          | 20      | 14   | 25          | 20      | 8.5  | 16          | 10      | -  | -           | -       | 6.5  | 16          | 10      | 4.9  | 10          | 6       |
| 5.5  | 7.5   | 7.5 | 0.85 | 83 | 20.6   | 35          | 25      | 18.9   | 35          | 25      | 11.5   | 20          | 16      | 11   | 20          | 16      | 8.9  | 16          | 10      | 6.7  | 16          | 10      |
| 7.5  | 10    | 10  | 0.86 | 85 | 27.4   | 35          | 35      | 24.8   | 35          | 35      | 15.5   | 25          | 20      | 14   | 25          | 16      | 11.9   | 20          | 16      | 9  | 16          | 10      |
| 8  | 11    | -   | 0.86 | 85 | 28.8   | 50          | 35      | 26.4   | 35          | 35      | 16.7   | 25          | 20      | -  | -           | -       | 12.7   | 20          | 16      | -  | -           | -       |
| 11   | 15    | 15  | 0.86 | 87 | 39.2   | 63          | 50      | 35.3   | 50          | 50      | 22   | 35          | 25      | 21   | 35          | 25      | 16.7   | 25          | 20      | 13   | 25          | 16      |
| 12.5   | 17    | -   | 0.86 | 87 | 43.8   | 63          | 50      | 40.2   | 63          | 50      | 25   | 35          | 35      | -  | -           | -       | 19   | 35          | 25      | -  | -           | -       |
| 15   | 20    | 20  | 0.86 | 87 | 52.6   | 80          | 63      | 48.2   | 80          | 63      | 30   | 50          | 35      | 28   | 35          | 35      | 22.5   | 35          | 25      | 17.5   | 25          | 20      |
| 18.5   | 25    | 25  | 0.86 | 88 | 64.9   | 100         | 80      | 58.7   | 80          | 63      | 37   | 63          | 50      | 35   | 50          | 50      | 28.5   | 50          | 35      | 21   | 35          | 25      |
| 20   | 27    | -   | 0.86 | 88 | 69.3   | 100         | 80      | 63.4   | 80          | 80      | 40   | 63          | 50      | -  | -           | -       | 30.6   | 50          | 35      | -  | -           | -       |
| 22   | 30    | 30  | 0.87 | 89 | 75.2   | 100         | 80      | 68   | 100         | 80      | 44   | 63          | 50      | 40   | 63          | 50      | 33   | 50          | 50      | 25   | 35          | 35      |
| 25   | 34    | -   | 0.87 | 89 | 84.4   | 125         | 100     | 77.2   | 100         | 100     | 50   | 80          | 63      | -  | -           | -       | 38   | 63          | 50      | -  | -           | -       |
| 30   | 40    | 40  | 0.87 | 90 | 101  | 125         | 125     | 92.7   | 125         | 100     | 60   | 80          | 63      | 55   | 80          | 63      | 44   | 63          | 50      | 33   | 50          | 35      |
| 37   | 50    | 50  | 0.87 | 90 | 124  | 160         | 160     | 114  | 160         | 125     | 72   | 100         | 80      | 66   | 100         | 80      | 54   | 80          | 63      | 42   | 63          | 50      |
| 40   | 54    | -   | 0.87 | 90 | 134  | 160         | 160     | 123  | 160         | 160     | 79   | 100         | 100     | -  | -           | -       | 60   | 80          | 63      | -  | -           | -       |
| 45   | 60    | 60  | 0.88 | 91 | 150  | 200         | 160     | 136  | 200         | 160     | 85   | 125         | 100     | 80   | 100         | 100     | 64.5   | 100         | 80      | 49   | 63          | 63      |
| 51   | 70    | -   | 0.88 | 91 | 168  | 200         | 200     | 154  | 200         | 200     | 97   | 125         | 100     | -  | -           | -       | 73.7   | 100         | 80      | -  | -           | -       |
| 55   | 75    | -   | 0.88 | 91 | 181  | 250         | 200     | 166  | 200         | 200     | 105  | 160         | 125     | -  | -           | -       | 79   | 125         | 100     | 60   | 80          | 63      |
| 59   | 80    | 80  | 0.88 | 91 | 194  | 250         | 250     | 178  | 250         | 200     | 112  | 160         | 125     | 105  | 160         | 125     | 85.3   | 125         | 100     | -  | -           | -       |
| 75   | 100   | 100 | 0.88 | 91 | 245  | 315         | 250     | 226  | 315         | 250     | 140  | 200         | 160     | 135  | 200         | 160     | 106  | 160         | 125     | 82   | 125         | 100     |
| 90   | 125   | 125 | 0.88 | 92 | 292  | 400         | 315     | 268  | 315         | 315     | 170  | 250         | 200     | 165  | 200         | 200     | 128  | 160         | 160     | 98   | 125         | 125     |
| 110  | 150   | 150 | 0.88 | 92 | 358  | 500         | 400     | 327  | 400         | 400     | 205  | 250         | 250     | 200  | 250         | 250     | 156  | 200         | 200     | 118  | 160         | 125     |
| 129  | 175   | 175 | 0.88 | 92 | 420  | 500         | 500     | 384  | 500         | 400     | 242  | 315         | 250     | 230  | 315         | 250     | 184  | 250         | 200     | -  | -           | -       |
| 132  | 180   | -   | 0.88 | 92 | 425  | 500         | 500     | 393  | 500         | 500     | 245  | 315         | 250     | -  | -           | -       | 186  | 250         | 200     | 140  | 200         | 160     |
| 147  | 200   | 200 | 0.88 | 93 | 472  | 630         | 630     | 432  | 630         | 500     | 273  | 315         | 315     | 260  | 315         | 315     | 207  | 250         | 250     | -  | -           | -       |
| 160  | 220   | -   | 0.88 | 93 | 502  | 630         | 630     | 471  | 630         | 630     | 295  | 400         | 315     | -  | -           | -       | 220  | 315         | 250     | 170  | 200         | 200     |
| 184  | 250   | 250 | 0.88 | 93 | 590  | 800         | 630     | 541  | 630         | 630     | 340  | 400         | 400     | 325  | 400         | 400     | 259  | 315         | 315     | -  | -           | -       |
| 200  | 270   | -   | 0.88 | 93 | 626  | 800         | 800     | 589  | 800         | 630     | 370  | 500         | 400     | -  | -           | -       | 278  | 315         | 315     | 215  | 250         | 250     |
| 220  | 300   | 300 | 0.88 | 93 | 700  | 1000        | 800     | 647  | 800         | 800     | 408  | 500         | 500     | 385  | 500         | 400     | 310  | 400         | 400     | -  | -           | -       |
| 250  | 340   | -   | 0.88 | 93 | 803  | 1000        | 1000    | 736  | 1000        | 800     | 460  | 630         | 500     | -  | -           | -       | 353  | 500         | 400     | 268  | 315         | 315     |
| 257  | 350   | 350 | 0.88 | 93 | 826  | 1000        | 1000    | 756  | 1000        | 800     | 475  | 630         | 630     | 450  | 630         | 500     | 363  | 500         | 400     | -  | -           | -       |
| 295  | 400   | 400 | 0.88 | 93 | 948  | 1250        | 1000    | 868  | 1000        | 1000    | 546  | 800         | 630     | 500  | 630         | 630     | 416  | 500         | 500     | -  | -           | -       |
| 315  | 430   | -   | 0.88 | 93 | 990  | 1250        | 1250    | 927  | 1250        | 1000    | 580  | 800         | 630     | -  | -           | -       | 445  | 630         | 500     | 337  | 400         | 400     |
| 355  | 483   | -   | 0.89 | 95 | -  | -           | -       | -  | -           | -       | 636  | 800         | 800     | -  | -           | -       | 483  | 630         | 630     | 366  | 500         | 400     |
| 400  | 545   | -   | 0.89 | 96 | -  | -           | -       | -  | -           | -       | 710  | 1000        | 800     | -  | -           | -       | 538  | 630         | 630     | 410  | 500         | 500     |

Low voltage switch gear

The motor F.L.C. be valid for standard internal and surface cooled three-pole motors with 1500 min<sup>-1</sup>. The fuses values be valid for the motor F.L.C. shown in the table and D.O.L.-start: starting current max. 6x motor F.L.C., starting time max. 5s; star-delta-start: starting current max. 2x motor F.L.C., starting time max. 15s. For motors with higher F.L.C., higher starting current and / or longer starting time, larger short-circuit fuses are required.

The maximum admissible value is dependent on the switchgear respectively thermal overload relay.

Approximate values of motor F.L.C. according to CSA and UL

| Motor rating<br>hp | Motor F.L.C. at 110-120V |              |              | Motor F.L.C. at 220-240V <sup>*1</sup> |              |              | Motor F.L.C. at 440-480V |              |              | Motor F.L.C. at 550-600V |              |              |
|--------------------|--------------------------|--------------|--------------|--|--------------|--------------|--------------------------|--------------|--------------|--------------------------|--------------|--------------|
|                    | 1-phase<br>A             | 2-phase<br>A | 3-phase<br>A | 1-phase<br>A                           | 2-phase<br>A | 3-phase<br>A | 1-phase<br>A             | 2-phase<br>A | 3-phase<br>A | 1-phase<br>A             | 2-phase<br>A | 3-phase<br>A |
| 1/2                | 9.8                      | 4.0          | 4.4          | 4.9                                    | 2.0          | 2.2          | 2.5                      | 1.0          | 1.1          | 2.0                      | 0.8          | 0.9          |
| 3/4                | 13.8                     | 4.8          | 6.4          | 6.9                                    | 2.4          | 3.2          | 3.5                      | 1.2          | 1.6          | 2.8                      | 1.0          | 1.3          |
| 1                  | 16.0                     | 6.4          | 8.4          | 8.0                                    | 3.2          | 4.2          | 4.0                      | 1.6          | 2.1          | 3.2                      | 1.3          | 1.7          |
| 1 1/2              | 20.0                     | 9.0          | 12.0         | 10.0                                   | 4.5          | 6.0          | 5.0                      | 2.3          | 3.0          | 4.0                      | 1.8          | 2.4          |
| 2                  | 24.0                     | 11.8         | 13.6         | 12.0                                   | 5.9          | 6.8          | 6.0                      | 3.0          | 3.4          | 4.8                      | 2.4          | 2.7          |
| 3                  | 34.0                     | 16.6         | 19.2         | 17.0                                   | 8.3          | 9.6          | 8.5                      | 4.2          | 4.8          | 6.8                      | 3.3          | 3.9          |
| 5                  | 56.0                     | 26.4         | 30.4         | 28.0                                   | 13.2         | 15.2         | 14.0                     | 6.6          | 7.6          | 11.2                     | 5.3          | 6.1          |
| 7 1/2              | 80.0                     | 38.0         | 44.0         | 40.0                                   | 19.0         | 22.0         | 21.0                     | 9.0          | 11.0         | 16.0                     | 8.0          | 9.0          |
| 10                 | 100.0                    | 48.0         | 56.0         | 50.0                                   | 24.0         | 28.0         | 26.0                     | 12.0         | 14.0         | 20.0                     | 10.0         | 11.0         |
| 15                 | 135.0                    | 72.0         | 84.0         | 68.0                                   | 36.0         | 42.0         | 34.0                     | 18.0         | 21.0         | 27.0                     | 14.0         | 17.0         |
| 20                 | -                        | 94.0         | 108.0        | 88.0                                   | 47.0         | 54.0         | 44.0                     | 23.0         | 27.0         | 35.0                     | 19.0         | 22.0         |
| 25                 | -                        | 118.0        | 136.0        | 110.0                                  | 59.0         | 68.0         | 55.0                     | 29.0         | 34.0         | 44.0                     | 24.0         | 27.0         |
| 30                 | -                        | 138.0        | 160.0        | 136.0                                  | 69.0         | 80.0         | 68.0                     | 35.0         | 40.0         | 54.0                     | 28.0         | 32.0         |
| 40                 | -                        | 180.0        | 208.0        | 176.0                                  | 90.0         | 104.0        | 88.0                     | 45.0         | 52.0         | 70.0                     | 36.0         | 41.0         |
| 50                 | -                        | 226.0        | 260.0        | 216.0                                  | 113.0        | 130.0        | 108.0                    | 56.0         | 65.0         | 86.0                     | 45.0         | 52.0         |
| 60                 | -                        | -            | -            | -                                      | 133.0        | 145.0        | -                        | 67.0         | 77.0         | -                        | 53.0         | 62.0         |
| 75                 | -                        | -            | -            | -                                      | 166.0        | 192.0        | -                        | 83.0         | 96.0         | -                        | 66.0         | 77.0         |
| 100                | -                        | -            | -            | -                                      | 218.0        | 248.0        | -                        | 109.0        | 124.0        | -                        | 87.0         | 99.0         |
| 125                | -                        | -            | -            | -                                      | -            | 312.0        | -                        | 135.0        | 156.0        | -                        | 108.0        | 125.0        |
| 150                | -                        | -            | -            | -                                      | -            | 360.0        | -                        | 156.0        | 180.0        | -                        | 125.0        | 144.0        |
| 200                | -                        | -            | -            | -                                      | -            | 480.0        | -                        | 208.0        | 240.0        | -                        | 167.0        | 192.0        |
| 250                | -                        | -            | -            | -                                      | -            | 602.0        | -                        | -            | 302.0        | -                        | -            | 242.0        |
| 300                | -                        | -            | -            | -                                      | -            | -            | -                        | -            | 361.0        | -                        | -            | 289.0        |
| 350                | -                        | -            | -            | -                                      | -            | -            | -                        | -            | 414.0        | -                        | -            | 336.0        |
| 400                | -                        | -            | -            | -                                      | -            | -            | -                        | -            | 477.0        | -                        | -            | 382.0        |
| 500                | -                        | -            | -            | -                                      | -            | -            | -                        | -            | 590.0        | -                        | -            | 472.0        |

\*1 Determine the motor current for 200V and 208V by increasing the values for 220-240V at 200V about 15% and for 208V about 10%.

Contactors

Data according to IEC 947-4-1, EN 60947-4-1, VDE 0660

| Main Contacts  | Type                 | J7KN-10   | J7KN-14    | J7KN-18    | J7KN-22   | J7KN-24   | J7KN-32   | J7KN-40     | J7KN-50   | J7KN-62   | J7KN-74   |
|--|----------------------|-----------|------------|------------|-----------|-----------|-----------|-------------|-----------|-----------|-----------|
| Rated insulation voltage $U_i$ <sup>1)</sup>                                   | V AC                 | 690       | 690        | 690        | 690       | 690       | 690       | 690         | 690       | 690       | 690       |
| Making capacity $I_m$  | at $U_n = 690V$ AC A | 200       | 200        | 200        | 200       | 400       | 500       | 500         | 700       | 900       | 900       |
| Breaking capacity $I_b$  | 400V AC A            | 180       | 180        | 200        | 200       | 380       | 400       | 400         | 600       | 800       | 800       |
| J7KN-10 to J7KN-22 $\cos\phi = 0,65$   | 500V AC A            | 150       | 150        | 180        | 180       | 300       | 370       | 370         | 500       | 700       | 700       |
| J7KN-24 to J7KN-72 $\cos\phi = 0,35$   | 690V AC A            | 100       | 100        | 150        | 150       | 260       | 340       | 340         | 400       | 500       | 500       |
|  | 1000V AC A           | -         | -          | -          | -         | -         | -         | -           | -         | -         | -         |
| <b>Utilization category AC1</b>  |                      |           |            |            |           |           |           |             |           |           |           |
| <b>Switching of resistive load</b>   |                      |           |            |            |           |           |           |             |           |           |           |
| Rated operational current $I_n (=I_{th})$ at 40°C, open                        | A                    | 25        | 25         | 32         | 32        | 50        | 65        | 80          | 110       | 120       | 130       |
| Rated operational power of three-phase resistive loads 50-60Hz, $\cos\phi = 1$ | 220V kW              | 9,5       | 9,5        | 12,2       | 12,2      | 19,0      | 24,7      | 30,4        | 41,9      | 45,7      | 49,5      |
|  | 230V kW              | 9,9       | 9,9        | 12,7       | 12,7      | 19,9      | 25,9      | 31,8        | 43,8      | 47,7      | 51,7      |
|  | 240V kW              | 10,4      | 10,4       | 13,3       | 13,3      | 20,8      | 27,0      | 33,2        | 45,7      | 49,8      | 54,0      |
|  | 380V kW              | 16,4      | 16,4       | 21,0       | 21,0      | 32,9      | 42,7      | 52,6        | 72,3      | 78,9      | 85,5      |
|  | 400V kW              | 17,3      | 17,3       | 22,1       | 22,1      | 34,6      | 45,0      | 55,4        | 76,1      | 83,0      | 90,0      |
|  | 415V kW              | 17,9      | 17,9       | 23,0       | 23,0      | 35,9      | 46,7      | 57,4        | 79,0      | 86,2      | 93,3      |
|  | 440V kW              | 19,0      | 19,0       | 24,4       | 24,4      | 38,1      | 49,5      | 60,9        | 83,7      | 91,3      | 99,0      |
|  | 500V kW              | 21,6      | 21,6       | 27,7       | 27,7      | 43,3      | 56,2      | 69,2        | 95,2      | 103,8     | 112,5     |
|  | 660V kW              | 28,5      | 28,5       | 36,5       | 36,5      | 57,1      | 74,2      | 91,3        | 125,6     | 137,0     | 148,4     |
|  | 690V kW              | 29,8      | 29,8       | 38,2       | 38,2      | 59,7      | 77,6      | 95,5        | 131,3     | 143,2     | 155,2     |
|  | 1000V kW             | -         | -          | -          | -         | -         | -         | -           | -         | -         | -         |
| Rated operational current $I_n (=I_{th})$ at 60°C, enclosed                    | A                    | 25        | 25         | 32         | 32        | 40        | 55        | 65          | 90        | 100       | 110       |
| Rated operational power of three-phase resistive loads 50-60Hz, $\cos\phi = 1$ | 220V kW              | 9,5       | 9,5        | 12,2       | 12,2      | 15,2      | 20,9      | 24,7        | 34,3      | 38,1      | 41,9      |
|  | 230V kW              | 9,9       | 9,9        | 12,7       | 12,7      | 15,9      | 21,9      | 25,9        | 35,8      | 39,8      | 43,8      |
|  | 240V kW              | 10,4      | 10,4       | 13,3       | 13,3      | 16,6      | 22,8      | 27,0        | 37,4      | 41,5      | 45,7      |
|  | 380V kW              | 16,4      | 16,4       | 21,0       | 21,0      | 26,3      | 36,2      | 42,7        | 59,2      | 65,7      | 72,3      |
|  | 400V kW              | 17,3      | 17,3       | 22,1       | 22,1      | 27,7      | 38,1      | 45,0        | 62,3      | 69,2      | 76,1      |
|  | 415V kW              | 17,9      | 17,9       | 23,0       | 23,0      | 28,7      | 39,5      | 46,7        | 64,6      | 71,8      | 79,0      |
|  | 440V kW              | 19,0      | 19,0       | 24,4       | 24,4      | 30,4      | 41,9      | 49,5        | 68,5      | 76,1      | 83,7      |
|  | 500V kW              | 21,6      | 21,6       | 27,7       | 27,7      | 34,6      | 47,6      | 56,2        | 77,9      | 86,5      | 95,2      |
|  | 660V kW              | 28,5      | 28,5       | 36,5       | 36,5      | 45,7      | 62,8      | 74,2        | 102,8     | 114,2     | 125,6     |
|  | 690V kW              | 29,8      | 29,8       | 38,2       | 38,2      | 47,7      | 65,7      | 77,6        | 107,4     | 119,4     | 131,3     |
|  | 1000V kW             | -         | -          | -          | -         | -         | -         | -           | -         | -         | -         |
| Minimum cross-section of conductor at load with $I_n (=I_{th})$                | mm <sup>2</sup>      | 4         | 4          | 6          | 6         | 10        | 16        | 25          | 35        | 50        | 50        |
| <b>Utilization category AC2 and AC3</b>  |                      |           |            |            |           |           |           |             |           |           |           |
| <b>Switching of three-phase motors</b>   |                      |           |            |            |           |           |           |             |           |           |           |
| Rated operational current $I_n$ open and enclosed                              | 220V A               | 12        | 15         | 18         | 22        | 24        | 30        | 40          | 50        | 63        | 74        |
|  | 230V A               | 11,5      | 14,5       | 18         | 22        | 24        | 30        | 40          | 50        | 62        | 74        |
|  | 240V A               | 11        | 14         | 18         | 22        | 24        | 32        | 40          | 50        | 62        | 74        |
|  | <b>380-400V A</b>    | <b>10</b> | <b>14</b>  | <b>18</b>  | <b>22</b> | <b>24</b> | <b>32</b> | <b>40</b>   | <b>50</b> | <b>62</b> | <b>74</b> |
|  | 415V A               | 9         | 14         | 18         | 22        | 23        | 30        | 40          | 50        | 62        | 74        |
|  | 440V A               | 9         | 14         | 18         | 22        | 23        | 30        | 40          | 50        | 62        | 74        |
|  | 500V A               | 7         | 9          | 9          | 9         | 17,5      | 21        | 21          | 33        | 42        | 42        |
|  | 660-690V A           | 6,5       | 8,5        | 8,5        | 8,5       | 17        | 20        | 20          | 31        | 40        | 40        |
|  | 1000V A              | -         | -          | -          | -         | -         | -         | -           | -         | -         | -         |
| Rated operational power of three-phase motors 50-60Hz                          | 220-230V kW          | 3         | 4          | 5          | 6         | 6         | 8,5       | 11          | 12,5      | 18,5      | 22        |
|  | 240V kW              | 3         | 4          | 5          | 7         | 7         | 9         | 11,5        | 13,5      | 19        | 23        |
|  | <b>380-400V kW</b>   | <b>4</b>  | <b>5,5</b> | <b>7,5</b> | <b>11</b> | <b>11</b> | <b>15</b> | <b>18,5</b> | <b>22</b> | <b>30</b> | <b>37</b> |
|  | 415V kW              | 4,5       | 6          | 8,5        | 12        | 12        | 16        | 20          | 24        | 33        | 40        |
|  | 440V kW              | 4,5       | 6          | 8,5        | 12        | 12        | 16        | 20          | 24        | 33        | 40        |
|  | 500V kW              | 5,5       | 7,5        | 10         | 10        | 15        | 18,5      | 18,5        | 30        | 37        | 45        |
|  | 660-690V kW          | 5,5       | 7,5        | 10         | 10        | 15        | 18,5      | 18,5        | 30        | 37        | 45        |
|  | 1000V kW             | -         | -          | -          | -         | -         | -         | -           | -         | -         | -         |
| <b>Utilization category AC4</b>  |                      |           |            |            |           |           |           |             |           |           |           |
| <b>Switching of squirrel cage motors, inching</b>                              |                      |           |            |            |           |           |           |             |           |           |           |
| Rated operational current $I_n (=I_{th})$ open and enclosed                    | 220V A               | 12        | 15         | 18         | 18        | 24        | 30        | 40          | 50        | 63        | 63        |
|  | 230V A               | 11,5      | 14,5       | 18         | 18        | 24        | 30        | 40          | 50        | 62        | 62        |
|  | 240V A               | 11        | 14         | 18         | 18        | 24        | 32        | 40          | 50        | 62        | 62        |
|  | <b>380-400V A</b>    | <b>10</b> | <b>14</b>  | <b>18</b>  | <b>18</b> | <b>24</b> | <b>32</b> | <b>40</b>   | <b>50</b> | <b>62</b> | <b>62</b> |
|  | 415V A               | 9         | 14         | 18         | 18        | 23        | 30        | 37          | 45        | 60        | 60        |
|  | 440V A               | 9         | 14         | 18         | 18        | 23        | 30        | 37          | 45        | 55        | 55        |
|  | 500V A               | 9         | 12         | 16         | 16        | 17,5      | 21        | 21          | 33        | 42        | 42        |
|  | 660V A               | 7         | 9          | 9          | 9         | 17        | 20        | 20          | 31        | 40        | 40        |
|  | 690V A               | 6,5       | 8,5        | 8,5        | 8,5       | 17        | 20        | 20          | 31        | 40        | 40        |
|  | 1000V A              | -         | -          | -          | -         | -         | -         | -           | -         | -         | -         |

Low voltage switch gear

| Main Contacts  |                       | Type      | J7KN-10  | J7KN-14    | J7KN-18    | J7KN-22    | J7KN-24   | J7KN-32   | J7KN-40     | J7KN-50   | J7KN-62   | J7KN-74           |
|--|-----------------------|-----------|----------|------------|------------|------------|-----------|-----------|-------------|-----------|-----------|-------------------|
| <b>Utilization category AC4</b>  |                       |           |          |            |            |            |           |           |             |           |           |                   |
| <b>Switching of squirrel cage motors, inching</b>                                |                       |           |          |            |            |            |           |           |             |           |           |                   |
| Rated operational power of three-phase motors 50-60Hz                            | 220-230V              | kW        | 3        | 4          | 5          | 5          | 6         | 8,5       | 11          | 12,5      | 18,5      | 18,5              |
|  | 240V                  | kW        | 3        | 4          | 5          | 5          | 7         | 9         | 11,5        | 13,5      | 19        | 19                |
|  | <b>380-400V</b>       | <b>kW</b> | <b>4</b> | <b>5,5</b> | <b>7,5</b> | <b>7,5</b> | <b>11</b> | <b>15</b> | <b>18,5</b> | <b>22</b> | <b>30</b> | <b>30</b>         |
|  | 415V                  | kW        | 4,5      | 6          | 8,5        | 8,5        | 12        | 16        | 20          | 24        | 33        | 33                |
|  | 440V                  | kW        | 4,5      | 6          | 8,5        | 8,5        | 12        | 16        | 20          | 24        | 33        | 33                |
|  | 500V                  | kW        | 5,5      | 7,5        | 10         | 10         | 15        | 18,5      | 18,5        | 30        | 37        | 37                |
|  | 660-690V              | kW        | 5,5      | 7,5        | 10         | 10         | 15        | 18,5      | 18,5        | 30        | 37        | 37                |
|  | 1000V                 | kW        | -        | -          | -          | -          | -         | -         | -           | -         | -         | -                 |
| <b>Utilization category AC 5a</b>  |                       |           |          |            |            |            |           |           |             |           |           |                   |
| <b>Switching of gas discharge lamps</b>  |                       |           |          |            |            |            |           |           |             |           |           |                   |
| Rated operational current I <sub>e</sub> , per pole at 220/230V                  |                       |           |          |            |            |            |           |           |             |           |           |                   |
| Fluorescent lamps,   |                       |           |          |            |            |            |           |           |             |           |           |                   |
| uncompensated and serial compensated   | A                     | 20        | 20       | 25         | 25         | 40         | 52        | 64        | 88          | 96        | 104       | 104               |
| parallel compensated   | A                     | 7         | 9        | 9          | 9          | 18         | 22        | 22        | 30          | 40        | 45        | 45                |
| dual-connection  | A                     | 22,5      | 22,5     | 28         | 28         | 45         | 58        | 72        | 98          | 108       | 117       | 117               |
| Metal halide lamps <sup>2</sup> ,  |                       |           |          |            |            |            |           |           |             |           |           |                   |
| uncompensated  | A                     | 12        | 15       | 19         | 19         | 30         | 39        | 48        | 66          | 72        | 78        | 78                |
| parallel compensated   | A                     | 7         | 9        | 9          | 9          | 18         | 22        | 22        | 30          | 40        | 45        | 45                |
| Mercury-vapour lamps <sup>3</sup> ,  |                       |           |          |            |            |            |           |           |             |           |           |                   |
| uncompensated  | A                     | 22,5      | 25       | 28         | 28         | 45         | 58        | 72        | 99          | 108       | 117       | 117               |
| parallel compensated   | A                     | 7         | 9        | 9          | 9          | 18         | 22        | 22        | 30          | 40        | 45        | 45                |
| Mixed light lamps <sup>4</sup>   | A                     | 20        | 20       | 25         | 25         | 40         | 52        | 64        | 88          | 96        | 104       | 104               |
| <b>Utilization category AC 5b</b>  |                       |           |          |            |            |            |           |           |             |           |           |                   |
| <b>Switching of incandescent lamps<sup>5</sup></b>                               |                       |           |          |            |            |            |           |           |             |           |           |                   |
| Rated operational current I <sub>e</sub> , per pole at 220/230V                  | A                     | 12,5      | 12,5     | 12,5       | 12,5       | 25         | 31        | 31        | 43          | 56        | 56        | 56                |
| <b>Utilization category AC 6a</b>  |                       |           |          |            |            |            |           |           |             |           |           |                   |
| <b>Transformer primary switching</b>   |                       |           |          |            |            |            |           |           |             |           |           |                   |
| at inrush  | n                     | 30        | 30       | 30         | 30         | 30         | 30        | 30        | 30          | 30        | 30        | 30                |
| Rated operational current I <sub>e</sub>   | 400V                  | A         | 4,5      | 5,5        | 7,5        | 7,5        | 10,5      | 13,5      | 13,5        | 20        | 27        | 33                |
| Rated operational power dependent on inrush n                                    | 220-230V              | kVA       | 1,8      | 2,2        | 3          | 3          | 4,2       | 5,4       | 5,4         | 8         | 10,7      | 13                |
|  | 240V                  | kVA       | 1,9      | 2,3        | 3,1        | 3,1        | 4,3       | 5,6       | 5,6         | 8,3       | 11,2      | 13,5              |
|  | 380-400V              | kVA       | 3,1      | 3,8        | 5,2        | 5,2        | 7,3       | 9,3       | 9,3         | 13,5      | 18,5      | 22,5              |
| For different inrush-factors x use the following formula: Px=Pn*(n/x)            | 415-440V              | kVA       | 3,4      | 4,2        | 5,7        | 5,7        | 8         | 10,2      | 10,2        | 15        | 20,5      | 25                |
|  | 500V                  | kVA       | 3,9      | 4,8        | 6,5        | 6,5        | 9         | 11,5      | 11,5        | 17        | 23        | 28                |
|  | 660-690V              | kVA       | 5,4      | 6,5        | 9          | 9          | 12,5      | 16        | 16          | 24        | 32        | 39                |
| <b>Utilization category AC 6b</b>  |                       |           |          |            |            |            |           |           |             |           |           |                   |
| <b>Switching of three-phase capacitor banks</b>                                  |                       |           |          |            |            |            |           |           |             |           |           |                   |
| Maximum inrush current (peak value) as multiple k of the capacitor rated current | k                     | 35        | 25       | 20         | 20         | 25         | 25        | 25        | 25          | 25        | 25        | 20                |
| Rated operational current I <sub>e</sub>   | 500V                  | A         | 8        | 12         | 15,5       | 15,5       | 23        | 32        | 32          | 45        | 60        | 70                |
| Rated operational power (sin <sup>-1</sup> )                                     | 220-230V              | kVA       | 3        | 4,5        | 6          | 6          | 8,5       | 12        | 12          | 17        | 24        | 28                |
|  | 240V                  | kVA       | 3,5      | 5          | 6,5        | 6,5        | 9,5       | 13        | 13          | 18,5      | 25        | 29                |
|  | 380-400V              | kVA       | 5        | 7,5        | 10         | 10         | 15        | 20        | 20          | 29        | 39        | 46                |
| For different multiples x use the following formula: Px=Pk*(k/x)                 | 415-440V              | kVA       | 5,5      | 8          | 11         | 11         | 16        | 22        | 22          | 32        | 43        | 50                |
|  | 500V                  | kVA       | 7        | 10         | 13         | 13         | 20        | 26        | 26          | 39        | 50        | 58                |
|  | 660-690V              | kVA       | 7        | 10         | 13         | 13         | 20        | 26        | 26          | 40        | 50        | 58                |
| <b>Switching of detuned capacitors</b>   |                       |           |          |            |            |            |           |           |             |           |           |                   |
| Rated operational current I <sub>e</sub>   | 690V                  | A         | 8        | 13         | 18         | 20         | 28        | 36        | 42          | 48        | 72        | 105 <sup>1)</sup> |
| Rated operational power  | 220-230V              | kVA       | 2,9      | 5          | 7          | 7,5        | 11        | 14        | 16          | 20        | 28        | 33                |
|  | 240V                  | kVA       | 3,1      | 5,4        | 7          | 8          | 11        | 14        | 17          | 20        | 28        | 36                |
|  | 380-400V              | kVA       | 5        | 9          | 12,5       | 13         | 20        | 25        | 27,5        | 33,3      | 50        | 75 <sup>1)</sup>  |
|  | 415-440V              | kVA       | 5,5      | 9,5        | 13         | 14         | 22        | 27        | 30          | 36        | 53        | 75 <sup>1)</sup>  |
|  | 500V                  | kVA       | 6        | 11         | 15         | 17         | 25        | 30        | 36          | 40        | 60        | 75                |
|  | 660-690V              | kVA       | 8        | 15         | 20         | 22         | 33        | 41        | 48          | 55        | 82        | 100               |
| <b>Utilization category DC1</b>  |                       |           |          |            |            |            |           |           |             |           |           |                   |
| <b>Switching of resistive load</b>   |                       |           |          |            |            |            |           |           |             |           |           |                   |
| Time constant L/R 1ms  |                       |           |          |            |            |            |           |           |             |           |           |                   |
| Rated operational current I <sub>e</sub>   | 1 pole 24V            | A         | 20       | 25         | 32         | 32         | 50        | 65        | 80          | 110       | 120       | 130               |
|  | 60V                   | A         | 20       | 25         | 32         | 32         | 50        | 65        | 80          | 110       | 120       | 130               |
|  | 110V                  | A         | 6        | 6          | 6          | 6          | 10        | 10        | 10          | 12        | 12        | 12                |
|  | 220V                  | A         | 0,8      | 0,8        | 0,8        | 0,8        | 1,4       | 1,4       | 1,4         | 1,4       | 1,4       | 1,4               |
|  | 3 poles in series 24V | A         | 20       | 25         | 32         | 32         | 50        | 65        | 80          | 110       | 120       | 130               |
|  | 60V                   | A         | 20       | 25         | 32         | 32         | 50        | 65        | 80          | 110       | 120       | 130               |
|  | 110V                  | A         | 20       | 25         | 32         | 32         | 50        | 65        | 80          | 110       | 120       | 130               |
|  | 220V                  | A         | 16       | 20         | 20         | 20         | 30        | 35        | 35          | 63        | 80        | 80                |



| Main Contacts   | Type  | J7KN-10                         | J7KN-14 | J7KN-18 | J7KN-22 | J7KN-24 | J7KN-32                 | J7KN-40 | J7KN-50 | J7KN-62                 | J7KN-74 |      |
|---|---|---------------------------------|---------|---------|---------|---------|-------------------------|---------|---------|-------------------------|---------|------|
| <b>Utilization category DC3 and DC5</b>   |   |                                 |         |         |         |         |                         |         |         |                         |         |      |
| <b>Switching of shunt motors and series motors</b>  |   |                                 |         |         |         |         |                         |         |         |                         |         |      |
| Time constant L/R   | 15ms  |                                 |         |         |         |         |                         |         |         |                         |         |      |
| Rated operational current I <sub>e</sub>  | 1 pole 24V A                                      | 20                              | 25      | 32      | 32      | 50      | 65                      | 80      | 110     | 120                     | 130     |      |
|   |   | 60V A                           | 6       | 6       | 6       | 6       | 30                      | 30      | 30      | 60                      | 60      | 60   |
|   | 3 poles in series 24V A                           | 110V A                          | 1,2     | 1,2     | 1,2     | 1,2     | 1,8                     | 1,8     | 1,8     | 1,8                     | 1,8     | 1,8  |
|   |   | 220V A                          | 0,2     | 0,2     | 0,2     | 0,2     | 0,2                     | 0,2     | 0,2     | 0,25                    | 0,25    | 0,25 |
|   |   | 60V A                           | 20      | 25      | 32      | 32      | 50                      | 65      | 80      | 110                     | 120     | 130  |
|   |   | 110V A                          | 20      | 20      | 20      | 20      | 40                      | 40      | 40      | 80                      | 80      | 80   |
|   |   | 220V A                          | 2,5     | 2,5     | 2,5     | 2,5     | 4                       | 4       | 4       | 5                       | 5       | 5    |
|   |   |                                 |         |         |         |         |                         |         |         |                         |         |      |
|   |   |                                 |         |         |         |         |                         |         |         |                         |         |      |
|   |   |                                 |         |         |         |         |                         |         |         |                         |         |      |
| <b>Maximum ambient temperature</b>  |   |                                 |         |         |         |         |                         |         |         |                         |         |      |
| Operation   | open °C   | -40 to +60 (+90) <sup>6</sup>   |         |         |         |         |                         |         |         |                         |         |      |
|   | enclosed °C                                       | -40 to +40                      |         |         |         |         |                         |         |         |                         |         |      |
| with thermal overload relay   | open °C   | -25 to +60                      |         |         |         |         |                         |         |         |                         |         |      |
|   | enclosed °C                                       | -25 to +40                      |         |         |         |         |                         |         |         |                         |         |      |
| Storage   | °C  | -50 to +90                      |         |         |         |         |                         |         |         |                         |         |      |
| <b>Short circuit protection</b>   |   |                                 |         |         |         |         |                         |         |         |                         |         |      |
| for contactors without thermal overload relay   |   |                                 |         |         |         |         |                         |         |         |                         |         |      |
| Coordination-type "1" according to IEC 947-4-1  |   |                                 |         |         |         |         |                         |         |         |                         |         |      |
| Contact welding without hazard of persons   |   |                                 |         |         |         |         |                         |         |         |                         |         |      |
| max. fuse size  | gL (gG) A   | 63                              | 63      | 63      | 63      | 80      | 80                      | 80      | 160     | 160                     | 160     |      |
| Coordination-type "2" according to IEC 947-4-1  |   |                                 |         |         |         |         |                         |         |         |                         |         |      |
| Light contact welding accepted  |   |                                 |         |         |         |         |                         |         |         |                         |         |      |
| max. fuse size  | gL (gG) A   | 25                              | 35      | 35      | 35      | 50      | 50                      | 50      | 100     | 125                     | 125     |      |
| Contact welding not accepted  |   |                                 |         |         |         |         |                         |         |         |                         |         |      |
| max. fuse size  | gL (gG) A   | 16                              | 16      | 16      | 16      | 25      | 35                      | 35      | 50      | 63                      | 63      |      |
| For contactors with thermal overload relay the device with the smaller admissible backup fuse (contactor or thermal overload relay) determines the fuse size. |   |                                 |         |         |         |         |                         |         |         |                         |         |      |
| <b>Cable cross-sections</b>   |   |                                 |         |         |         |         |                         |         |         |                         |         |      |
| for contactors without thermal overload relay   |   |                                 |         |         |         |         |                         |         |         |                         |         |      |
| main connector  | solid or stranded mm <sup>2</sup>                 | 0,75 - 6                        |         |         |         |         | 1,5 - 25                |         |         | 4 - 50                  |         |      |
|   | flexible mm <sup>2</sup>                          | 1 - 4                           |         |         |         |         | 2,5 - 16                |         |         | 10 - 35                 |         |      |
|   | flexible with multicore cable end mm <sup>2</sup> | 0,75 - 4                        |         |         |         |         | 1,5 - 16                |         |         | 6 - 35                  |         |      |
| Cables per clamp  |   | 2                               |         |         |         |         | 1                       |         |         | 1                       |         |      |
|   | solid or stranded mm <sup>2</sup>                 | 6+(1-6) / 4+(0,75-4)            |         |         |         |         | 16+(2,5-6) / 10+(4-10)  |         |         | 50+4 / 35+6 / 25+(6-16) |         |      |
|   | flexible mm <sup>2</sup>                          | 2,5+(0,75-2,5) / 1,5+(0,75-1,5) |         |         |         |         | 6+(4-6) / 4+(2,5-4)     |         |         | 16+(6-16) / 10+(6-16)   |         |      |
| Cables per clamp  |   | 2                               |         |         |         |         | 2                       |         |         | 2                       |         |      |
|   | solid AWG   | 18 - 10                         |         |         |         |         | 16 - 10                 |         |         | 12 - 10                 |         |      |
|   | flexible AWG                                      | 18 - 10                         |         |         |         |         | 14 - 4                  |         |         | 10 - 0                  |         |      |
| Cables per clamp  |   | 2                               |         |         |         |         | 1                       |         |         | 1                       |         |      |
|   | solid AWG   | 10+(16-10) / 12+(18-12)         |         |         |         |         | 10+(16-10) / 12+(18-12) |         |         | 10+(12-10) / 12+12      |         |      |
|   | flexible AWG                                      | 14+(18-14) / 16+(18-16)         |         |         |         |         | 14+(18-14) / 16+(18-16) |         |         | 1+(12-10) / 2+(8-12)    |         |      |
| Cables per clamp  |   | 2                               |         |         |         |         | 2                       |         |         | 2                       |         |      |
|   | solid AWG   | 10+(14-10) / 12+(18-12)         |         |         |         |         | 4+(18-12) / 6+(18-8)    |         |         | 3+(12-8) / 4+(10-6)     |         |      |
|   | flexible AWG                                      | 14+(18-14) / 16+(18-16)         |         |         |         |         | 8+(18-8) / 10+(18-12)   |         |         |                         |         |      |
| <b>Frequency of operations z</b>  |   |                                 |         |         |         |         |                         |         |         |                         |         |      |
| Contactors without thermal overload relay   |   |                                 |         |         |         |         |                         |         |         |                         |         |      |
|   | without load 1/h                                  | 10000                           | 10000   | 10000   | 10000   | 7000    | 7000                    | 7000    | 7000    | 7000                    | 7000    |      |
|   | AC3, I <sub>e</sub> 1/h                           | 600                             | 600     | 600     | 600     | 600     | 600                     | 600     | 400     | 400                     | 400     |      |
|   | AC4, I <sub>e</sub> 1/h                           | 120                             | 120     | 120     | 120     | 120     | 120                     | 120     | 120     | 120                     | 120     |      |
|   | DC3, I <sub>e</sub> 1/h                           | 600                             | 600     | 600     | 600     | 600     | 600                     | 600     | 400     | 400                     | 400     |      |
| <b>Mechanical life</b>  |   |                                 |         |         |         |         |                         |         |         |                         |         |      |
| AC operated   | S x 10 <sup>6</sup>                               | 10                              | 10      | 10      | 10      | 10      | 10                      | 10      | 10      | 10                      | 10      |      |
| DC operated   | S x 10 <sup>6</sup>                               | 10                              | 10      | 10      | 10      | 10      | 10                      | 10      | 10      | 10                      | 10      |      |
| DC solenoid operated  | S x 10 <sup>6</sup>                               | 50                              | 50      | 50      | 50      | -       | -                       | -       | -       | -                       | -       |      |
| <b>Short time current</b>   | 10s-current A                                     | 96                              | 120     | 144     | 176     | 184     | 240                     | 296     | 360     | 504                     | 592     |      |
| <b>Power loss per pole</b>  | at I <sub>e</sub> /AC3 400V W                     | 0,21                            | 0,35    | 0,5     | 0,75    | 0,7     | 1,3                     | 2       | 2,2     | 3,9                     | 5,5     |      |
| <b>Resistance to shock acc. to IEC 68-2-27</b>  |   |                                 |         |         |         |         |                         |         |         |                         |         |      |
| Shock time 20ms sine-wave   | NO g  | 10                              | 10      | 10      | 10      | 8       | 8                       | 8       | 8       | 8                       | 8       |      |
|   | NC g  | 6                               | 6       | 6       | 6       | -       | -                       | -       | -       | -                       | -       |      |

Low voltage switch gear

<sup>1</sup> Suitable at 690V for: earthed-neutral systems, overvoltage I to IV, pollution degree 3 (standard-industry): U<sub>imp</sub> = 8kV. Data for other conditions on request.

<sup>2</sup> Metal halide lamps and sodium-vapour lamps (high- and low-pressure lamps)

<sup>3</sup> High-pressure lamps

<sup>4</sup> Blended lamps, containing a mercury high-pressure unit and a tungsten helix in a fluorescent glass bulb (daylight lamps)

<sup>5</sup> Current inrush approx. 16 x I<sub>e</sub>

<sup>6</sup> With reduced control voltage range 0,9 up to 1,0 x U<sub>s</sub> and with reduced rated current I<sub>e</sub>/AC1 according to I<sub>e</sub>/AC3

| Main Contacts  |  | Type            | J7KN-85 | J7KN-110 | J7KN-151 | J7KN-176 | J7KN-200 |
|--|--|-----------------|---------|----------|----------|----------|----------|
| Rated insulation voltage $U_i$ <sup>1)</sup>                                   |  | V AC            | 750     | 750      | 690      | 690      | 690      |
| Making capacity $I_m$ at $U_e = 690V$ AC A                                     |  | A               | 1100    | 1200     | 1500     | 1800     | 1700     |
| Breaking capacity $I_b$ 400V AC A  |  | A               | 950     | 1100     | 1200     | 1400     | 1600     |
| J7KN-10 to J7KN-22 $\cos\phi = 0,65$   |  | 500V AC A       | 850     | 1000     | 1200     | 1400     | 1600     |
| J7KN-24 to J7KN-72 $\cos\phi = 0,35$   |  | 690V AC A       | 600     | 600      | 700      | 800      | 1200     |
|  |  | 1000V AC A      | -       | -        | -        | -        | -        |
| <b>Utilization category AC1</b>  |  |                 |         |          |          |          |          |
| <b>Switching of resistive load</b>   |  |                 |         |          |          |          |          |
| Rated operational current $I_c (=I_n)$ at 40°C, open                           |  | A               | 150     | 170      | 230      | 250      | 350      |
| Rated operational power of three-phase resistive loads 50-60Hz, $\cos\phi = 1$ |  | 220V kW         | 57      | 64       | 87       | 95       | 133      |
|  |  | 230V kW         | 59      | 67       | 91       | 99       | 139      |
|  |  | 240V kW         | 62      | 70       | 95       | 103      | 145      |
|  |  | 380V kW         | 98      | 111      | 151      | 164      | 230      |
|  |  | 400V kW         | 103     | 117      | 159      | 173      | 242      |
|  |  | 415V kW         | 107     | 122      | 165      | 179      | 251      |
|  |  | 440V kW         | 114     | 129      | 175      | 190      | 266      |
|  |  | 500V kW         | 130     | 147      | 199      | 216      | 303      |
|  |  | 660V kW         | 171     | 194      | 262      | 285      | 400      |
|  |  | 690V kW         | 179     | 203      | 274      | 298      | 418      |
|  |  | 1000V kW        | -       | -        | 398      | 433      | -        |
| Rated operational current $I_c (=I_n)$ at 60°C, enclosed                       |  | A               | 100     | 125      | 180      | 200      | 280      |
| Rated operational power of three-phase resistive loads 50-60Hz, $\cos\phi = 1$ |  | 220V kW         | 38      | 47       | 68       | 76       | 106      |
|  |  | 230V kW         | 40      | 49       | 71       | 79       | 111      |
|  |  | 240V kW         | 41      | 52       | 74       | 83       | 116      |
|  |  | 380V kW         | 65      | 82       | 118      | 131      | 184      |
|  |  | 400V kW         | 69      | 86       | 124      | 138      | 193      |
|  |  | 415V kW         | 71      | 89       | 129      | 143      | 201      |
|  |  | 440V kW         | 71      | 95       | 137      | 152      | 213      |
|  |  | 500V kW         | 86      | 108      | 155      | 173      | 242      |
|  |  | 660V kW         | 114     | 142      | 205      | 228      | 320      |
|  |  | 690V kW         | 119     | 149      | 215      | 239      | 334      |
|  |  | 1000V kW        | -       | -        | -        | -        | -        |
| Minimum cross-section of conductor at load with $I_c (=I_n)$                   |  | mm <sup>2</sup> | 50      | 70       | 95       | 120      | 185      |
| <b>Utilization category AC2 and AC3</b>  |  |                 |         |          |          |          |          |
| <b>Switching of three-phase motors</b>   |  |                 |         |          |          |          |          |
| Rated operational current $I_c$ open and enclosed                              |  | 220V A          | 85      | 110      | 150      | 175      | 210      |
|  |  | 230V A          | 85      | 110      | 150      | 175      | 210      |
|  |  | 240V A          | 85      | 110      | 150      | 175      | 210      |
|  |  | 380-400V A      | 85      | 110      | 150      | 175      | 210      |
|  |  | 415V A          | 85      | 110      | 150      | 175      | 210      |
|  |  | 440V A          | 85      | 110      | 150      | 175      | 210      |
|  |  | 500V A          | 60      | 60       | 150      | 175      | 210      |
|  |  | 660-690V A      | 57,5    | 57,5     | 120      | 140      | 150      |
|  |  | 1000V A         | -       | -        | 60       | 70       | -        |
| Rated operational power of three-phase motors 50-60Hz                          |  | 220-230V kW     | 25      | 33       | 40       | 50       | 60       |
|  |  | 240V kW         | 27      | 35       | 45       | 55       | 65       |
|  |  | 380-400V kW     | 45      | 55       | 75       | 90       | 110      |
|  |  | 415V kW         | 49      | 63       | 80       | 95       | 115      |
|  |  | 440V kW         | 49      | 63       | 85       | 100      | 125      |
|  |  | 500V kW         | 55      | 75       | 90       | 100      | 132      |
|  |  | 660-690V kW     | 55      | 55       | 110      | 132      | 132      |
|  |  | 1000V kW        | -       | -        | 75       | 90       | -        |
| <b>Utilization category AC4</b>  |  |                 |         |          |          |          |          |
| <b>Switching of squirrel cage motors, inching</b>                              |  |                 |         |          |          |          |          |
| Rated operational current $I_c (=I_n)$ open and enclosed                       |  | 220V A          | 85      | 98       | 55       | 63       | 85       |
|  |  | 230V A          | 85      | 98       | 55       | 63       | 85       |
|  |  | 240V A          | 85      | 98       | 55       | 63       | 85       |
|  |  | 380-400V A      | 85      | 85       | 55       | 63       | 85       |
|  |  | 415V A          | 85      | 85       | 55       | 63       | 85       |
|  |  | 440V A          | 85      | 85       | 55       | 63       | 85       |
|  |  | 500V A          | 85      | 85       | -        | -        | -        |
|  |  | 660V A          | 60      | 60       | -        | -        | -        |
|  |  | 690V A          | 57,5    | 57,5     | -        | -        | -        |
|  |  | 1000V A         | -       | -        | -        | -        | -        |

| Main Contacts  |                   | Type   | J7KN-85 | J7KN-110 | J7KN-151 | J7KN-176 | J7KN-200 |
|--|-------------------|--------|---------|----------|----------|----------|----------|
| Rated operational power of three-phase motors 50-60Hz                            | 220-230V          | kW     | 25      | 30       | 15       | 18,5     | 25       |
|  | 240V              | kW     | 27      | 32       | 15,5     | 19       | 26       |
|  | 380-400V          | kW     | 45      | 45       | 25       | 30       | 45       |
|  | 415V              | kW     | 49      | 49       | 25       | 33       | 45       |
|  | 440V              | kW     | 49      | 49       | 30       | 34       | 48       |
|  | 500V              | kW     | 55      | 55       | 25       | 30       | 55       |
|  | 660-690V          | kW     | 55      | 55       | 25       | 30       | 55       |
|  | 1000V             | kW     | -       | -        | -        | -        | -        |
| <b>Utilization category AC 5a</b>  |                   |        |         |          |          |          |          |
| <b>Switching of gas discharge lamps</b>  |                   |        |         |          |          |          |          |
| Rated operational current I <sub>o</sub> per pole at 220/230V                    |                   |        |         |          |          |          |          |
| Fluorescent lamps,   |                   |        |         |          |          |          |          |
| uncompensated and serial compensated   | A                 | 100    | 120     | 120      | 140      | 180      |          |
| parallel compensated   | A                 | 55     | 70      | 85       | 100      | 120      |          |
| dual-connection  | A                 | 112    | 144     | 120      | 140      | 180      |          |
| Metal halide lamps <sup>2</sup> ,  |                   |        |         |          |          |          |          |
| uncompensated  | A                 | 85     | 90      | 95       | 110      | 140      |          |
| parallel compensated   | A                 | 55     | 70      | 75       | 85       | 110      |          |
| Mercury-vapour lamps <sup>3</sup> ,  |                   |        |         |          |          |          |          |
| uncompensated  | A                 | 112    | 144     | 120      | 140      | 180      |          |
| parallel compensated   | A                 | 55     | 70      | 75       | 85       | 110      |          |
| Mixed light lamps <sup>4</sup>   | A                 | 100    | 120     | 100      | 120      | 160      |          |
| <b>Utilization category AC5b</b>   |                   |        |         |          |          |          |          |
| <b>Switching of incandescent lamps<sup>5</sup></b>                               |                   |        |         |          |          |          |          |
| Rated operational current I <sub>o</sub> per pole at 220/230V                    | A                 | 69     | 75      | 100      | 120      | 160      |          |
| <b>Utilization category AC6a</b>   |                   |        |         |          |          |          |          |
| <b>Transformer primary switching</b>   |                   |        |         |          |          |          |          |
| at inrush  | n                 | 30     | 30      | 30       | 30       | 30       |          |
| Rated operational current I <sub>o</sub>   | 400V A            | 38     | 50      | 65       | 80       | 90       |          |
| Rated operational power dependent on inrush n                                    | 220-230V          | kVA    | 15      | 20       | 25       | 30       | 34       |
|  | 240V              | kVA    | 15,5    | 20,5     | 27       | 33       | 37       |
|  | 380-400V          | kVA    | 26      | 34       | 45       | 55       | 60       |
| For different inrush-factors x use the following formula: Px=Pn*(n/x)            | 415-440V          | kVA    | 29      | 38       | 46       | 57       | 63       |
|  | 500V              | kVA    | 33      | 43       | 55       | 69       | 75       |
|  | 660-690V          | kVA    | 45      | 60       | 56       | 69       | 100      |
| <b>Utilization category AC6b</b>   |                   |        |         |          |          |          |          |
| <b>Switching of three-phase capacitor banks</b>                                  |                   |        |         |          |          |          |          |
| Maximum inrush current (peak value) as multiple k of the capacitor rated current | k                 | 20     | 20      | 20       | 20       | 15       |          |
| Rated operational current I <sub>o</sub>   | 500V A            | 87     | 100     | 120      | 155      | 195      |          |
| Rated operational power (sin <sup>-1</sup> )                                     | 220-230V          | kVAr   | 33      | 38       | 45       | 60       | 75       |
|  | 240V              | kVAr   | 36      | 42       | 52       | 62       | 78       |
|  | 380-400V          | kVAr   | 57      | 65       | 80       | 100      | 130      |
| For different multiples x use the following formula: Px=Pk*(k/x)                 | 415-440V          | kVAr   | 60      | 70       | 95       | 110      | 135      |
|  | 500V              | kVAr   | 70      | 80       | 100      | 130      | 170      |
|  | 660-690V          | kVAr   | 70      | 80       | 100      | 130      | 170      |
| <b>Switching of detuned capacitors</b>   |                   |        |         |          |          |          |          |
| Rated operational current I <sub>o</sub>   | 690V A            | 98     | 105     | 115      | 140      | 200      |          |
| Rated operational power  | 220-230V          | kVAr   | 35      | 40       | 43       | 53       | 76       |
|  | 240V              | kVAr   | 39      | 43       | 45       | 55       | 80       |
|  | 380-400V          | kVAr   | 68      | 75       | 75       | 90       | 130      |
|  | 415-440V          | kVAr   | 71      | 77       | 80       | 100      | 140      |
|  | 500V              | kVAr   | 85      | 90       | 95       | 120      | 170      |
|  | 660-690V          | kVAr   | 110     | 120      | 125      | 150      | 200      |
| <b>Utilization category DC1</b>  |                   |        |         |          |          |          |          |
| <b>Switching of resistive load</b>   |                   |        |         |          |          |          |          |
| Time constant L/R 1ms  |                   |        |         |          |          |          |          |
| Rated operational current I <sub>o</sub>   | 1 pole            | 24V A  | 150     | 170      | -        | -        | -        |
|  |                   | 60V A  | 150     | 170      | -        | -        | -        |
|  |                   | 110V A | 20      | 25       | -        | -        | -        |
|  |                   | 220V A | 2       | 2,5      | -        | -        | -        |
|  | 3 poles in series | 24V A  | 150     | 170      | -        | -        | -        |
|  |                   | 60V A  | 150     | 170      | -        | -        | -        |
|  |                   | 110V A | 150     | 170      | -        | -        | -        |
|  |                   | 220V A | 100     | 160      | -        | -        | -        |

Low voltage switch gear

| Main Contacts   |   | Type                          | J7KN-85              | J7KN-110 | J7KN-151                      | J7KN-176 | J7KN-200 |
|---|---|-------------------------------|----------------------|----------|-------------------------------|----------|----------|
| <b>Utilization category DC3 and DC5</b>   |   |                               |                      |          |                               |          |          |
| <b>Switching of shunt motors and series motors</b>  |   |                               |                      |          |                               |          |          |
| Time constant L/R 15ms  |   |                               |                      |          |                               |          |          |
| Rated operational current I <sub>o</sub>  | 1 pole 24V A                                      | 150                           | 170                  | -        | -                             | -        | -        |
|   |   | 60V A                         | 85                   | 110      | -                             | -        | -        |
|   |   | 110V A                        | 2                    | 2,5      | -                             | -        | -        |
|   |   | 220V A                        | 0,5                  | 0,5      | -                             | -        | -        |
|   | 3 poles in series 24V A                           | 150                           | 170                  | -        | -                             | -        | -        |
|   |   | 60V A                         | 100                  | 110      | -                             | -        | -        |
|   |   | 110V A                        | 100                  | 110      | -                             | -        | -        |
|   |   | 220V A                        | 7                    | 8        | -                             | -        | -        |
| <b>Maximum ambient temperature</b>  |   |                               |                      |          |                               |          |          |
| Operation   | open °C   | -40 to +60 (+90) <sup>6</sup> |                      |          | -25 to +55 (+70) <sup>7</sup> |          |          |
|   | enclosed °C                                       | -40 to +40                    |                      |          | -25 to +40                    |          |          |
| with thermal overload relay   | open °C   | -25 to +60                    |                      |          | -25 to +55                    |          |          |
|   | enclosed °C                                       | -25 to +40                    |                      |          | -25 to +40                    |          |          |
| Storage   | °C  | -50 to +90                    |                      |          | -55 to +80                    |          |          |
| <b>Short circuit protection</b><br>for contactors without thermal overload relay  |   |                               |                      |          |                               |          |          |
| Coordination-type "1" according to IEC 947-4-1<br>Contact welding without hazard of persons   |   |                               |                      |          |                               |          |          |
| max. fuse size  | gL (gG) A   | 250                           | 250                  | 250      | 315                           | 400      |          |
| Coordination-type "2" according to IEC 947-4-1<br>Light contact welding accepted  |   |                               |                      |          |                               |          |          |
| max. fuse size  | gL (gG) A   | 160                           | 200                  | 200      | 250                           | 315      |          |
| Contact welding not accepted  |   |                               |                      |          |                               |          |          |
| max. fuse size  | gL (gG) A   | 100                           | 125                  | 160      | 200                           | 250      |          |
| For contactors with thermal overload relay the device with the smaller admissible backup fuse (contactor or thermal overload relay) determines the fuse size. |   |                               |                      |          |                               |          |          |
| <b>Cable cross-sections</b><br>for contactors without thermal overload relay  |   |                               |                      |          |                               |          |          |
| main connector  | solid or stranded mm <sup>2</sup>                 | 10 - 70 <sup>8</sup>          | 10 - 70 <sup>8</sup> | 95       | 120                           | 185      |          |
|   | flexible mm <sup>2</sup>                          | 6 - 50 <sup>8</sup>           | 16 - 50 <sup>8</sup> | screw    | screw                         | screw    |          |
|   | flexible with multicore cable end mm <sup>2</sup> | 10 - 35                       | 10 - 35              | M8       | M8                            | M8       |          |
| Cables per clamp  | solid or stranded mm <sup>2</sup>                 |                               |                      |          |                               |          |          |
|   | flexible mm <sup>2</sup>                          |                               |                      |          |                               |          |          |
| main connector  | solid AWG   | 10                            | 10                   |          |                               |          |          |
|   | flexible AWG                                      | 6 - 0                         | 6 - 0                |          |                               |          |          |
|   | solid AWG   | 1                             | 1                    |          |                               |          |          |
|   | flexible AWG                                      |                               |                      |          |                               |          |          |
| Cables per clamp  |   |                               |                      |          |                               |          |          |
|   |   |                               |                      |          |                               |          |          |
| <b>Frequency of operations z</b><br>Contactors without thermal overload relay   |   |                               |                      |          |                               |          |          |
|   | without load 1/h                                  | 3000                          | 3000                 | 1200     | 1200                          | 1200     |          |
|   | AC3, I <sub>o</sub> 1/h                           | 300                           | 300                  | -        | -                             | -        |          |
|   | AC4, I <sub>o</sub> 1/h                           | 120                           | 120                  | -        | -                             | -        |          |
|   | DC3, I <sub>o</sub> 1/h                           | 300                           | 300                  | -        | -                             | -        |          |
| <b>Mechanical life</b>  |   |                               |                      |          |                               |          |          |
| AC operated   | S x 10 <sup>6</sup>                               | 5                             | 5                    | 10       | 10                            | 8        |          |
| DC operated   | S x 10 <sup>6</sup>                               | 5                             | 5                    | 10       | 10                            | 8        |          |
| <b>Short time current</b>   | 10s-current A                                     | 680                           | 880                  | 1200     | 1400                          | 1800     |          |
| <b>Power loss per pole</b>  | at I <sub>o</sub> /AC3 400V W                     | 4,3                           | 6,0                  | 8        | 11                            | 8        |          |
| <b>Resistance to shock acc. to IEC 68-2-27</b>  |   |                               |                      |          |                               |          |          |
| Shock time 20ms sine-wave   | NO g  | 7                             | 7                    | -        | -                             | -        |          |
|   | NC g  | 5                             | 5                    | -        | -                             | -        |          |

<sup>1</sup> Suitable at 690V for: earthed-neutral systems, overvoltage I to IV, pollution degree 3 (standard-industry): U<sub>imp</sub> = 8kV. Data for other conditions on request.

<sup>2</sup> Metal halide lamps and sodium-vapour lamps (high- and low-pressure lamps)

<sup>3</sup> High-pressure lamps

<sup>4</sup> Blended lamps, containing a mercury high-pressure unit and a tungsten helix in a fluorescent glass bulb (daylight lamps)

<sup>5</sup> Current inrush approx. 16 x I<sub>o</sub>

<sup>6</sup> With reduced control voltage range 0,9 up to 1,0 x U<sub>s</sub> and with reduced rated current I<sub>o</sub>/AC1 according to I<sub>o</sub>/AC3

<sup>7</sup> With reduced control voltage range 1,0 x U<sub>s</sub> and with reduced rated current I<sub>o</sub>/AC1 according to I<sub>o</sub>/AC3

<sup>8</sup> Maximum cable cross-section with prepared conductor

## Contactors

### Data according to IEC 947-4-1, EN 60947-4-1, VDE 0660

| Auxiliary Contacts  | Type  | J7KN-10            | J7KN-14 | J7KN-18 | J7KN-22 | J7KN-24  | J7KN-32 | J7KN-40 | J7KN-50  | J7KN-62 | J7KN-74 |
|---|---|--------------------|---------|---------|---------|----------|---------|---------|----------|---------|---------|
| <b>Rated insulation voltage <math>U_i</math><sup>1</sup></b>  | V~  | 690                | 690     | 690     | 690     | -        | -       | -       | -        | -       | -       |
| <b>Thermal rated current <math>I_n</math> to 690V</b>   |   |                    |         |         |         |          |         |         |          |         |         |
| Ambient temperature   | 40°C A  | 16                 | 16      | 16      | 16      | -        | -       | -       | -        | -       | -       |
|   | 60°C A  | 12                 | 12      | 12      | 12      | -        | -       | -       | -        | -       | -       |
| <b>Utilization category AC15</b>  |   |                    |         |         |         |          |         |         |          |         |         |
| Rated operational current $I_e$   | 220-240V A  | 12                 | 12      | 12      | 12      | -        | -       | -       | -        | -       | -       |
|   | 380-415V A  | 4                  | 4       | 4       | 4       | -        | -       | -       | -        | -       | -       |
|   | 440V A  | 4                  | 4       | 4       | 4       | -        | -       | -       | -        | -       | -       |
|   | 500V A  | 3                  | 3       | 3       | 3       | -        | -       | -       | -        | -       | -       |
|   | 660-690V A  | 1                  | 1       | 1       | 1       | -        | -       | -       | -        | -       | -       |
| <b>Utilization category DC13</b>  |   |                    |         |         |         |          |         |         |          |         |         |
| Rated operational current $I_e$   | 60V A   | 8                  | 8       | 8       | 8       | -        | -       | -       | -        | -       | -       |
|   | 110V A  | 1                  | 1       | 1       | 1       | -        | -       | -       | -        | -       | -       |
|   | 220V A  | 0,1                | 0,1     | 0,1     | 0,1     | -        | -       | -       | -        | -       | -       |
| <b>Short circuit protection</b>   |   |                    |         |         |         |          |         |         |          |         |         |
| short-circuit current 1kA,<br>contact welding not accepted  |   |                    |         |         |         |          |         |         |          |         |         |
| max. fuse size  | gL (gG) A   | 25                 | 25      | 25      | 25      | -        | -       | -       | -        | -       | -       |
| For contactors with thermal overload relay the device with the smaller admissible control fuse (contactor or thermal overload relay) determines the fuse. |   |                    |         |         |         |          |         |         |          |         |         |
| <b>Control Circuit</b>  |   |                    |         |         |         |          |         |         |          |         |         |
| <b>Power consumption of coils</b>   |   |                    |         |         |         |          |         |         |          |         |         |
| AC operated   | inrush VA   | 33-45              |         |         |         | 90-115   |         |         | 140-165  |         |         |
|   | sealed VA   | 7-10               |         |         |         | 9-13     |         |         | 13-18    |         |         |
|   | W   | 2,6-3              |         |         |         | 2,7-4    |         |         | 5,4-7    |         |         |
| DC operated   | inrush W  | 75                 |         |         |         | 140      |         |         | 200      |         |         |
|   | sealed W  | 2                  |         |         |         | 2        |         |         | 6        |         |         |
| DC solenoid operated<br>(J7KNG-types)   | inrush W  | 3                  |         |         |         | -        |         |         | -        |         |         |
|   | sealed W  | 3                  |         |         |         | -        |         |         | -        |         |         |
| <b>Operation range of coils</b>   |   |                    |         |         |         |          |         |         |          |         |         |
| in multiples of control voltage $U_c$   | AC operated                                       | 0,85-1,1           |         |         |         | 0,85-1,1 |         |         | 0,85-1,1 |         |         |
|   | DC operated                                       | 0,8-1,1            |         |         |         | 0,8-1,1  |         |         | 0,8-1,1  |         |         |
| <b>Switching time at control voltage <math>U_c</math>, <math>\pm 10\%^{2,3}</math></b>  |   |                    |         |         |         |          |         |         |          |         |         |
| AC operated   | make time ms                                      | 8-16               |         |         |         | 10-25    |         |         | 12-28    |         |         |
|   | release time ms                                   | 5-13               |         |         |         | 8-15     |         |         | 8-15     |         |         |
|   | arc duration ms                                   | 10-15              |         |         |         | 10-15    |         |         | 10-15    |         |         |
| DC operated   | make time ms                                      | 8-12               |         |         |         | 10-20    |         |         | 12-23    |         |         |
|   | release time ms                                   | 8-13               |         |         |         | 10-15    |         |         | 10-18    |         |         |
|   | arc duration ms                                   | 10-15              |         |         |         | 10-15    |         |         | 10-15    |         |         |
| DC solenoid operated  | make time ms                                      | 65-85              |         |         |         | -        |         |         | -        |         |         |
|   | release time ms                                   | 20-30 <sup>4</sup> |         |         |         | -        |         |         | -        |         |         |
|   | arc duration ms                                   | 10-15              |         |         |         | -        |         |         | -        |         |         |
| <b>Cable cross-section</b>  |   |                    |         |         |         |          |         |         |          |         |         |
| Auxiliary connector   | solid mm <sup>2</sup>                             | 0,75-6             |         |         |         | -        |         |         | -        |         |         |
|   | flexible mm <sup>2</sup>                          | 1-4                |         |         |         | -        |         |         | -        |         |         |
| flexible with multicore cable end   | mm <sup>2</sup>                                   | 0,75-4             |         |         |         | -        |         |         | -        |         |         |
| Magnet coil   | solid mm <sup>2</sup>                             | 0,75-2,5           |         |         |         | 0,75-2,5 |         |         | 0,75-2,5 |         |         |
|   | flexible mm <sup>2</sup>                          | 0,5-2,5            |         |         |         | 0,5-2,5  |         |         | 0,5-2,5  |         |         |
|   | flexible with multicore cable end mm <sup>2</sup> | 0,5-1,5            |         |         |         | 0,5-1,5  |         |         | 0,5-1,5  |         |         |
| Clamps per pole   |   | 2                  |         |         |         | 2        |         |         | 2        |         |         |
| Auxiliary connector   | solid AWG   | 18 - 10            |         |         |         | -        |         |         | -        |         |         |
|   | flexible AWG                                      | 18 - 10            |         |         |         | -        |         |         | -        |         |         |
| Magnet coil   | solid AWG   | 14 - 12            |         |         |         | 14 - 12  |         |         | 14 - 12  |         |         |
|   | flexible AWG                                      | 18 - 12            |         |         |         | 18 - 12  |         |         | 18 - 12  |         |         |
| Clamps per pole   |   | 2                  |         |         |         | 2        |         |         | 2        |         |         |

Low voltage switch gear

<sup>1</sup> Suitable for: earthed-neutral systems, overvoltage category I to IV, pollution degree 3 (standard-industry):  $U_{imp} = 8kV$ . Data for other conditions on request

<sup>2</sup> Total breaking time = release time + arc duration

<sup>3</sup> Values for delay of the release time of the making contact and the make time of the break contact will be increased, if magnet coils are protected against voltage peaks (varistor, RC-unit, diode-unit)

<sup>4</sup> with integrated suppressor

| Auxiliary Contacts  |  | Type  | J7KN-85  | J7KN-110 | J7KN-151 | J7KN-176 | J7KN-200 |
|---|--|---|----------|----------|----------|----------|----------|
| Rated insulation voltage $U_i$ <sup>*1</sup>  |  | V~  | 690      | 690      | 690      | 690      | 690      |
| Thermal rated current $I_n$ to 690V   |  |   |          |          |          |          |          |
| Ambient temperature   |  | 40°C A  | 16       | 16       | 10       | 10       | 10       |
|   |  | 60°C A  | 12       | 12       | -        | -        | -        |
| <b>Utilization category AC15</b>  |  |   |          |          |          |          |          |
| Rated operational current $I_n$   |  | 220-240V A  | 12       | 12       | 3        | 3        | 3        |
|   |  | 380-415V A  | 6        | 6        | 2        | 2        | 2        |
|   |  | 440V A  | 6        | 6        | 1,5      | 1,5      | 1,5      |
|   |  | 500V A  | 4        | 4        | 1,5      | 1,5      | 1,5      |
|   |  | 660-690V A  | 2        | 2        | 1        | 1        | 1        |
| <b>Utilization category DC13</b>  |  |   |          |          |          |          |          |
| Rated operational current $I_n$   |  | 60V A   | 8        | 8        | -        | -        | -        |
|   |  | 110V A  | 1        | 1        | 0,5      | 0,5      | 1        |
|   |  | 220V A  | 0,1      | 0,1      | 0,2      | 0,2      | 0,5      |
| <b>Short circuit protection</b>   |  |   |          |          |          |          |          |
| short-circuit current 1kA,<br>contact welding not accepted  |  |   |          |          |          |          |          |
| max. fuse size  |  | gL (gG) A   | 25       | 25       | 10       | 10       | 10       |
| For contactors with thermal overload relay the device with the smaller admissible control fuse (contactor or thermal overload relay) determines the fuse. |  |   |          |          |          |          |          |
| <b>Control Circuit</b>  |  |   |          |          |          |          |          |
| <b>Power consumption of coils</b>   |  |   |          |          |          |          |          |
| AC operated   |  | inrush VA   | 280-350  | 350-420  | 350      | 350      | 1100     |
|   |  | sealed VA   | 16 -23   | 23 -29   | 5        | 5        | 66       |
|   |  | W   | 4-6      | 6-7,3    | -        | -        | -        |
| DC operated   |  | inrush W  | 170      | 320      | 350      | 350      | 530      |
|   |  | sealed W  | 2        | 4        | 5        | 5        | 21       |
| <b>Operation range of coils</b>   |  |   |          |          |          |          |          |
| in multiples of control voltage $U_c$   |  | AC operated                                       | 0,85-1,1 |          | 0,85-1,1 | 0,85-1,1 | 0,85-1,1 |
|   |  | DC operated                                       | 0,8-1,1  |          | 0,85-1,1 | 0,85-1,1 | 0,85-1,1 |
| <b>Switching time</b> at control voltage $U_c$ $\pm 10\%$ <sup>*2, *3</sup>   |  |   |          |          |          |          |          |
| AC operated   |  | make time ms                                      | 13-30    |          | 30-60    | 30-60    | 30-40    |
|   |  | release time ms                                   | 8-15     |          | 30-80    | 30-80    | 15-45    |
|   |  | arc duration ms                                   | 10-15    |          | -        | -        | -        |
| DC operated   |  | make time ms                                      | 20-30    |          | -        | -        | -        |
|   |  | release time ms                                   | 10-18    |          | -        | -        | -        |
|   |  | arc duration ms                                   | 10-15    |          | -        | -        | -        |
| <b>Cable cross-section</b>  |  |   |          |          |          |          |          |
| Auxiliary connector   |  | solid mm <sup>2</sup>                             | 0,75-2,5 |          | -        |          | 0,75-2,5 |
|   |  | flexible mm <sup>2</sup>                          | 0,75-2,5 |          | -        |          | 0,75-2,5 |
| flexible with multicore cable end   |  | mm <sup>2</sup>                                   | 0,5-1,5  |          | -        |          | -        |
| Magnet coil   |  | solid mm <sup>2</sup>                             | 0,75-2,5 |          | 1-2,5    |          | -        |
|   |  | flexible mm <sup>2</sup>                          | 0,5-2,5  |          | 1-2,5    |          | -        |
|   |  | flexible with multicore cable end mm <sup>2</sup> | 0,5-1,5  |          | -        |          | -        |
| Clamps per pole   |  |   | 14 - 12  |          | 16 - 12  |          | -        |
| Auxiliary connector   |  | solid AWG   | 18 - 12  |          | -        |          | 16 - 12  |
|   |  | flexible AWG                                      | 14 - 12  |          | -        |          | 16 - 12  |
| Magnet coil   |  | solid AWG   | 18 - 12  |          | 16 - 12  |          | -        |
|   |  | flexible AWG                                      | 2        |          | 2        |          | -        |
| Clamps per pole   |  |   | 0,75-2,5 |          | 0,75-2,5 |          | -        |

\*1 Suitable for: earthed-neutral systems, overvoltage category I to IV, pollution degree 3 (standard-industry):  $U_{imp} = 8kV$ . Data for other conditions on request

\*2 Total breaking time = release time + arc duration

\*3 Values for delay of the release time of the making contact and the make time of the break contact will be increased, if magnet coils are protected against voltage peaks (varistor, RC-unit, diode-unit)

**Contactors for North America**

**Data according to UL508**

| Main Contacts (cULus)   | Type        | J7KN-10     | J7KN-14     | J7KN-18     | J7KN-22     | J7KN-24     | J7KN-32     | J7KN-40     | J7KN-50     | J7KN-62     | J7KN-74     |
|---|-------------|-------------|-------------|-------------|-------------|-------------|-------------|-------------|-------------|-------------|-------------|
| Rated operational current "General Use"                                   | A           | 25          | 25          | 30          | 30          | 50          | 65          | 80          | 110         | 120         | 130         |
| Rated operational power of three-phase motors at 60Hz (3ph)               | 110-120V hp | 1½          | 2           | 2           | 3           | 5           | 5           | 7½          | 10          | 10          | 10          |
|   | 200V hp     | 3           | 3           | 5           | 5           | 7½          | 10          | 10          | 15          | 20          | 25          |
|   | 220-240V hp | 3           | 3           | 7½          | 7½          | 10          | 10          | 15          | 20          | 25          | 30          |
|   | 277V hp     | 3           | 5           | 7½          | 7½          | 10          | 15          | 20          | 25          | 30          | 30          |
|   | 380-415V hp | 5           | 5           | 10          | 10          | 10          | 15          | 20          | 25          | 30          | 40          |
|   | 440-480V hp | 5           | 7½          | 10          | 15          | 15          | 20          | 25          | 30          | 40          | 50          |
| Rated operational power of AC motors at 60Hz (1ph)                        | 110-120V hp | ½           | ¾           | 1           | 1½          | 1½          | 2           | 3           | 3           | 5           | 7½          |
|   | 200V hp     | 1           | 1,5         | 2           | 3           | 3           | 5           | 7½          | 7½          | 10          | 15          |
|   | 220-240V hp | 1½          | 2           | 3           | 3           | 5           | 5           | 7½          | 10          | 15          | 15          |
|   | 277V hp     | 2           | 3           | 3           | 5           | 5           | 7½          | 10          | 10          | 15          | 15          |
|   | 380-415V hp | 3           | 3           | 5           | 5           | 5           | 7½          | 10          | 15          | 20          | 20          |
|   | 440-480V hp | 3           | 5           | 5           | 7½          | 7½          | 10          | 15          | 20          | 25          | 25          |
| Rated operational power of three-phase motors at 60Hz (3ph) for elevators | 110-120V hp | -           | -           | -           | -           | 2           | 3           | -           | 3           | 5           | -           |
|   | 200V hp     | -           | -           | -           | -           | 3           | 5           | -           | 7½          | 10          | -           |
|   | 220-240V hp | -           | -           | -           | -           | 5           | 7½          | -           | 7½          | 10          | -           |
| Demands according to ANSI A17.5 (500.000 operations)                      | 440-480V hp | -           | -           | -           | -           | 10          | 15          | -           | 20          | 25          | -           |
|   | 550-600V hp | -           | -           | -           | -           | 10          | 20          | -           | 25          | 30          | -           |
| Rated operational current   | 600V A      | -           | -           | -           | -           | 15          | 22          | -           | 27          | 37          | -           |
| Fuses   | A           | 30          | 40          | 50          | 50          | 90          | 125         | 175         | 175         | 225         | 250         |
| Suitable for use on a capability of delivering not more than (SCCR)       | rms A<br>V  | 5000<br>600 | 5000<br>600 | 5000<br>600 | 5000<br>600 | 5000<br>600 | 5000<br>600 | 5000<br>600 | 5000<br>600 | 5000<br>600 | 5000<br>600 |
| Auxiliary Contacts (cULus)  |             | A600        | A600        | A600        | A600        | -           | -           | -           | -           | -           | -           |

| Main Contacts (cULus)   | Type        | J7KN-85      | J7KN-110     | J7KN-151     | J7KN-176     | J7KN-200 |
|---|-------------|--------------|--------------|--------------|--------------|----------|
| Rated operational current "General Use"                                   | A           | 125          | 125          | 180          | 220          | -        |
| Rated operational power of three-phase motors at 60Hz (3ph)               | 110-120V hp | 15           | -            | -            | -            | -        |
|   | 200V hp     | -            | 30           | 40           | 50           | -        |
|   | 220-240V hp | 35           | 40           | 50           | 60           | -        |
|   | 277V hp     | -            | -            | -            | -            | -        |
|   | 380-415V hp | -            | -            | -            | -            | -        |
|   | 440-480V hp | 65           | 75           | 100          | 125          | -        |
| Rated operational power of AC motors at 60Hz (1ph)                        | 110-120V hp | 8            | 10           | 15           | 25           | -        |
|   | 200V hp     | -            | 20           | -            | -            | -        |
|   | 220-240V hp | 20           | 20           | 25           | 30           | -        |
|   | 277V hp     | -            | -            | -            | -            | -        |
|   | 380-415V hp | -            | -            | -            | -            | -        |
|   | 440-480V hp | -            | 50           | -            | -            | -        |
| Rated operational power of three-phase motors at 60Hz (3ph) for elevators | 110-120V hp | -            | -            | -            | -            | -        |
|   | 200V hp     | -            | -            | -            | -            | -        |
|   | 220-240V hp | -            | -            | -            | -            | -        |
| Demands according to ANSI A17.5 (500.000 operations)                      | 440-480V hp | -            | -            | -            | -            | -        |
|   | 550-600V hp | -            | -            | -            | -            | -        |
| Rated operational current   | 600V A      | -            | 62           | -            | -            | -        |
| Fuses   | A           | -            | 300          | 300          | 500          | -        |
| Suitable for use on a capability of delivering not more than (SCCR)       | rms A<br>V  | 10000<br>600 | 10000<br>600 | 10000<br>600 | 10000<br>600 | -        |
| Auxiliary Contacts (cULus)  |             | A600         | A600         | -            | -            | -        |

Low voltage switch gear

# Contactors

## Data according to IEC 947-4-1, EN 60947-4-1, VDE 0660

### Contact Life

For selection of the suitable contactor-type according to supply voltage, power rating and application (utilization category AC1, AC3 or AC4) use contact life characteristic diagram.

For the most common supply voltages four scales of power ratings  $P_n$  are provided for each utilization category.

Select contactor-type according to utilization category **AC3** (breaking current  $I_a = I_n$ ) using the **motor rating** scales to the right, according to utilization category **AC4** (breaking current  $I_a = 6 \times I_n$ ) using the **motor rating** scales to the left.<sup>1</sup>

Select contactor-type according to utilization category **AC1** (breaking current  $I_a = I_n/AC1$ ) using the **breaking current** scale.<sup>1</sup>

For contactors frequently used under AC3/AC4-mixed service conditions calculate contact life with the formula:

$$M = \frac{AC3}{1 + \frac{\%AC4}{100} \times \left(\frac{AC3}{AC4} - 1\right)}$$

M = Contact life (switching cycles) for AC3/AC4-mixed operations

AC3 = Contact life (switching cycles) for AC3 operations (normal switching conditions). Breaking current  $I_a$  = rated motor current  $I_n$ .

AC4 = Contact life (switching cycles) for AC4 operations (inching).

Breaking current  $I_a$  = multiples of rated motor current  $I_n$ .

%AC4 = Percents of AC4-operations related to the total cycles.

1. Pay attention to the approved rated values of the selected contactor according to the national approvals

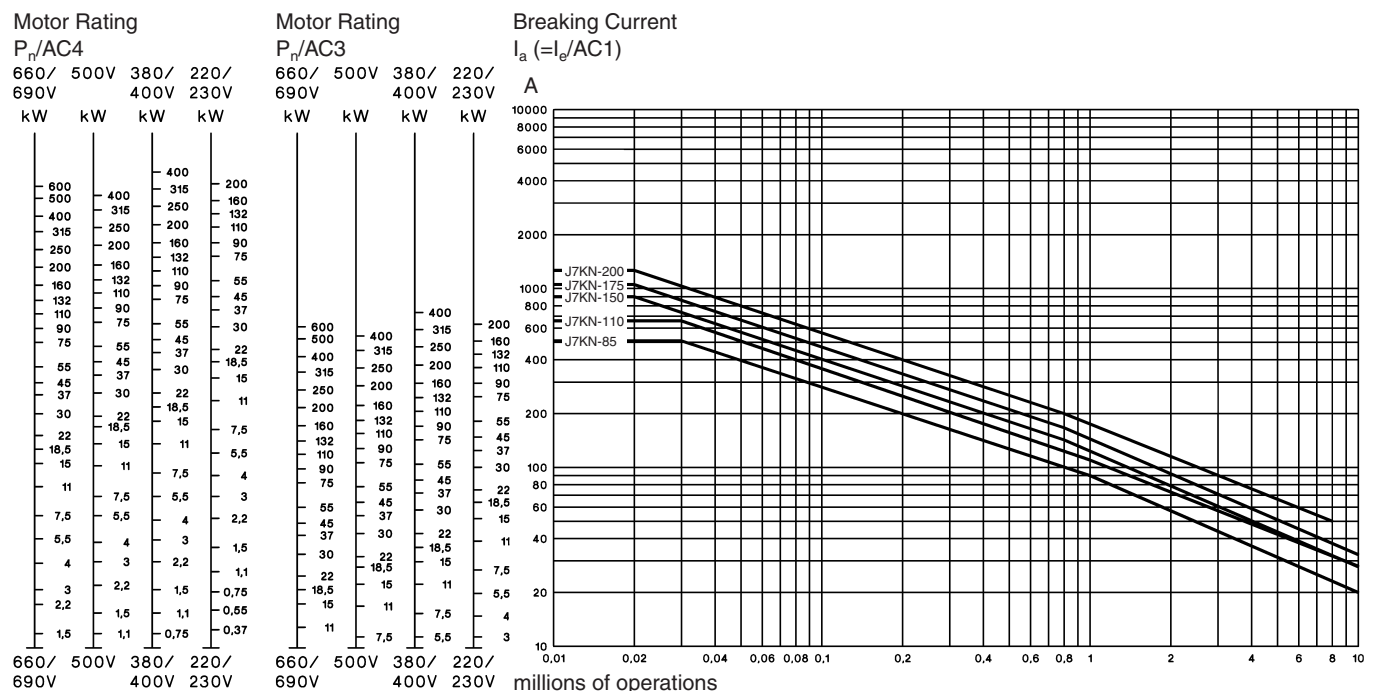
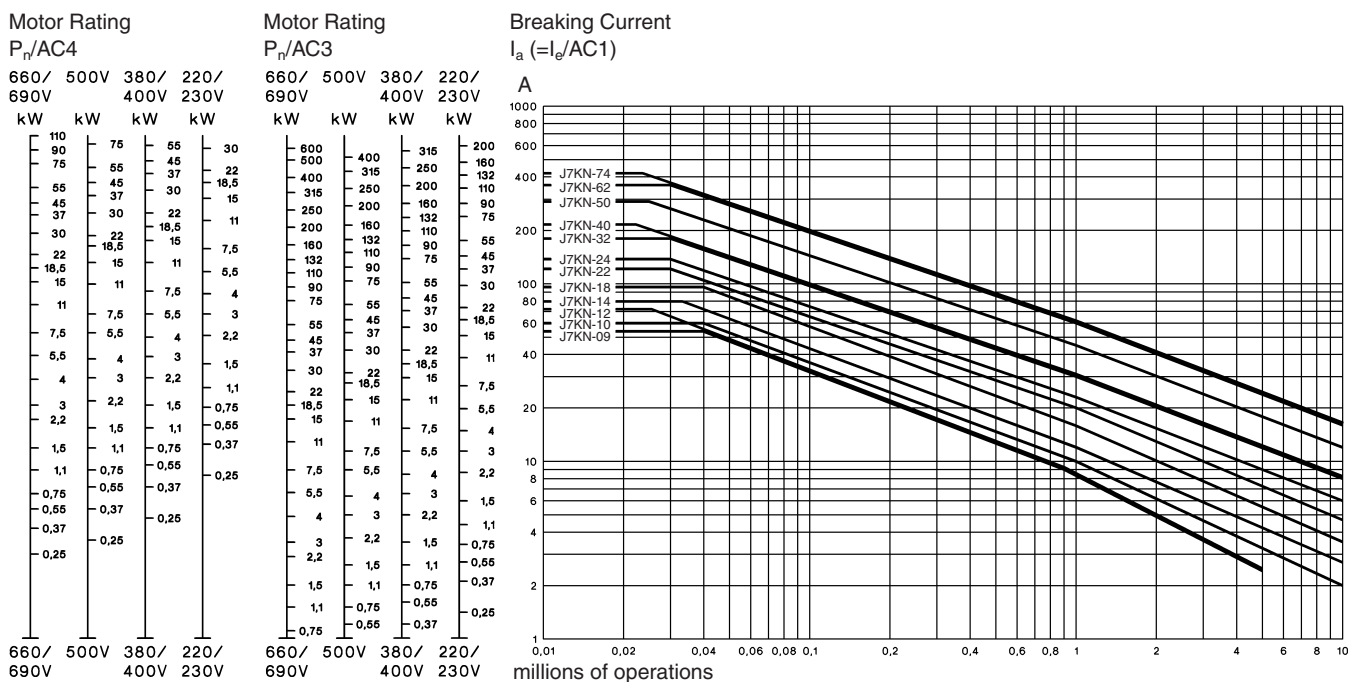



# Contactors

## Utilization Categories

For easier choice of devices and in order to make the comparison of different products simpler are utilization categories for contactors and motor-starters according to IEC 947-4-1 and VDE 0660 Part 102 ,for

control circuit devices and switching elements according to IEC 947-5-1 and VDE 0660 Part 200 determind. The table offers different utilization categories, typical applications and assorted test conditions.

| Type of current     | Category  | Typical applications   | Rated operational current | Test conditions for the number of on-load operating cycles |      |          |             |       |          | Test conditions for making and breaking capacities |      |          |             |       |          |
|---------------------|---|--|---------------------------|--|------|----------|-------------|-------|----------|--|------|----------|-------------|-------|----------|
|                     |   |  |                           | Make I/le  | U/Ur | cos      | Break Ic/le | Ur/Ur | cos      | Make I/le  | U/Ur | cos      | Break Ic/le | Ur/Ur | cos      |
| Alternating Current | AC1   | Non-inductive or slightly inductive loads-resistance furnaces                    | all values                | 1  | 1    | 0.95     | 1           | 1     | 0.95     | 1.5  | 1.05 | 0.8      | 1.5         | 1.05  | 0.8      |
|                     | AC2   | Slip-ring motors: starting, switching off  | all values                | 2.5  | 1    | 0.65     | 2.5         | 1     | 0.65     | 4  | 1.05 | 0.65     | 4           | 1.05  | 0.65     |
|                     | AC3   | Squirrel-cage motors: starting, switching off motors during running              | 17A< le 17A               | 6  | 1    | 0.65     | 1           | 0.17  | 0.65     | 10   | 1.05 | 0.45     | 8           | 1.05  | 0.45     |
|                     |   |  | le 100A                   | 6  | 1    | 0.35     | 1           | 0.17  | 0.35     | 10   | 1.05 | 0.45     | 8           | 1.05  | 0.45     |
|                     |   |  | le> 100A                  | 6  | 1    | 0.35     | 1           | 0.17  | 0.35     | 10   | 1.05 | 0.35     | 8           | 1.05  | 0.35     |
|                     | AC4   | Squirrel-cage motors: starting, plugging, inching                                | 17A< le 17A               | 6  | 1    | 0.65     | 6           | 1     | 0.65     | 12   | 1.05 | 0.45     | 10          | 1.05  | 0.45     |
|                     |   |  | le 100A                   | 6  | 1    | 0.35     | 6           | 1     | 0.35     | 12   | 1.05 | 0.45     | 10          | 1.05  | 0.45     |
|                     |   |  | le> 100A                  | 6  | 1    | 0.35     | 6           | 1     | 0.35     | 12   | 1.05 | 0.35     | 10          | 1.05  | 0.35     |
|                     | AC5a  | Switching of electric discharge lamp controls                                    | all values                | -  | -    | -        | -           | -     | -        | 3  | 1.05 | 0.45     | 3           | 1.05  | 0.45     |
|                     | AC5b  | Switching of incandescent lamps  | all values                | -  | -    | -        | -           | -     | -        | 1.5  | 1.05 | 1)       | 4           | 1.05  | 1)       |
|                     | AC6a  | Switching of transformers  | le 100A                   | -  | -    | -        | -           | -     | -        | 4.5  | 1.05 | 0.45     | 3.6         | 1.05  | 0.45     |
|                     |   |  | le> 100A                  | -  | -    | -        | -           | -     | -        | 4.5  | 1.05 | 0.35     | 3.6         | 1.05  | 0.35     |
|                     | AC6b  | Switching of capacitor banks   | -                         | -  | -    | -        | -           | -     | -        | 2)   |      |          | 2)          |       |          |
|                     | AC7a  | Slightly inductive loads in household appliances and similar applications        | all values                | -  | -    | -        | -           | -     | -        | 1.5  | 1.05 | 0.8      | 1.5         | 1.05  | 0.8      |
|                     | AC7b  | Motor loads for household applications   | le 100A                   | -  | -    | -        | -           | -     | -        | 8  | 1.05 | 0.45     | 6           | 1.05  | 0.45     |
| le> 100A            |   |  | -                         | -  | -    | -        | -           | -     | 8        | 1.05   | 0.35 | 6        | 1.05        | 0.35  |          |
| AC8a                | Hermetic refrigerant compressor motor control with manualresetting of overload releases     | le 100A  | -                         | -  | -    | -        | -           | -     | 6        | 1.05   | 0.45 | 6        | 1.05        | 0.45  |          |
|                     |   | le> 100A   | -                         | -  | -    | -        | -           | -     | 6        | 1.05   | 0.35 | 6        | 1.05        | 0.35  |          |
| AC8b                | Hermetic refrigerant compressor motor control with automatic resetting of overload releases | le 100A  | -                         | -  | -    | -        | -           | -     | 6        | 1.05   | 0.45 | 6        | 1.05        | 0.45  |          |
|                     |   | le> 100A   | -                         | -  | -    | -        | -           | -     | 6        | 1.05   | 0.35 | 6        | 1.05        | 0.35  |          |
| AC12                | Control of resistive loads and solid state loads with isolation by opto couplers            | all values   | -                         | -  | -    | -        | -           | -     | 1        | 1  | 0.9  | 1        | 1           | 0.9   |          |
| AC13                | Control of solid state loads with transformer isolation                                     | all values   | -                         | -  | -    | -        | -           | -     | 10       | 1.1  | 0.65 | 1.1      | 1.1         | 0.65  |          |
| AC14                | Control of small electromagnetic loads (<=72VA)   | -  | -                         | -  | -    | -        | -           | -     | 6        | 1.1  | 0.7  | 6        | 1.1         | 0.7   |          |
| AC15                | Control of electromagnetic load (>72VA)   | -  | -                         | 10   | 1    | 0.7      | 1           | 1     | 0.4      | 10   | 1.1  | 0.3      | 10          | 1.1   | 0.3      |
|                     |   |  |                           | Make I/le  | U/Ur | L/R [ms] | Break Ic/le | Ur/Ur | L/R [ms] | Make I/le  | U/Ur | L/R [ms] | Break Ic/le | Ur/Ur | L/R [ms] |
| Direct Current      | DC1   | Non-inductive or slightly inductive loads resistance furnaces                    | all values                | 1  | 1    | 1        | 1           | 1     | 1        | 1.5  | 1.05 | 1        | 1.5         | 1.05  | 1        |
|                     | DC3   | Shunt-motors: starting, plugging, inching dynamic braking of d.c. motors         | all values                | 2.5  | 1    | 2        | 2.5         | 1     | 2        | 4  | 1.05 | 2.5      | 4           | 1.05  | 2.5      |
|                     | DC5   | Series-motors: starting, plugging, inching dynamic braking of d.c. motors        | all values                | 2.5  | 1    | 7.5      | 2.5         | 1     | 7.5      | 4  | 1.05 | 15       | 4           | 1.05  | 15       |
|                     | DC6   | Switching of incandescent lamps  | all values                | -  | -    | -        | -           | -     | -        | 1.5  | 1.05 | 1)       | 4           | 1.05  | 1)       |
|                     | DC12  | Control of resistive loads and solid state loads with isolation by opto couplers | all values                | -  | -    | -        | -           | -     | -        | 1  | 1    | 1        | 1           | 1     | 1        |
|                     | DC13  | Control of electromagnets  | all values                | 1  | 1    | 300      | 1           | 1     | 300      | 1.1  | 1.1  | 300      | 1.1         | 1.1   | 300      |
|                     | DC14  | Control of electromagnetic loads having economy resistors in circuit             | all values                | -  | -    | -        | -           | -     | -        | 10   | 1.1  | 15       | 10          | 1.1   | 15       |

U, Rated operational voltage, U Voltage before make, U, Recovery voltage, I, Rated operational current, I Current make, I, Current broken

- 1) Test with incandescent lamps
- 2) Test conditions according to standard

Low voltage switch gear

## Accessories

### Data according to IEC 947-5-1, EN 60947-5-1, VDE 0660

| Auxiliary Contacts   | Type  | J73KN-B  | J73KN-C  | J73KN-D  | J74KN-B-TP... |
|--|---|----------|----------|----------|---------------|
| Rated insulation voltage $U_i^{*1}$  | V~  | 690      | 690      | 690      | 690           |
| Thermal rated current $I_n$ to 690V  |   |          |          |          |               |
| Ambient temperature  | 40°C A  | 10       | 10       | 10       | 10            |
|  | 60°C A  | 6        | 6        |          | -             |
| Frequency of operations z  | 1/h   | 3000     | 3000     | 3000     | 1200          |
| Mechanical life  | S x $10^6$  | 10       | 10       | 10       | 1             |
| Power loss per pole at I/AC1   | W   | 0,5      | 0,5      | -        | -             |
| Utilization category AC15  |   |          |          |          |               |
| Rated operational current $I_n$  | 220-240V A  | 3        | 3        | 3        | 4             |
|  | 380-400V A  | 2        | 2        | 2        | 3             |
|  | 440V A  | 1,6      | 1,6      | 1,5      | 2             |
|  | 500V A  | 1,2      | 1,2      | 1,5      | 2             |
|  | 660-690V A  | 0,6      | 0,6      | 1        | 2             |
| Utilization category DC13  |   |          |          |          |               |
| Rated operational current $I_n$  | 60V A   | 2        | 2        | -        | 2,5           |
|  | 110V A  | 0,4      | 0,4      | 1        | 1,5           |
|  | 220V A  | 0,1      | 0,1      | 0,5      | 0,2           |
| Short circuit protection   |   |          |          |          |               |
| short-circuit current 1kA, contact welding not accepted max. fuse size   | gL (gG) A   | 20       | 20       | 10       | 10            |
| For contactors with thermal overload relay or auxiliary contacts the device with the smaller admissible control fuse (contactor or thermal overload relay) determines the fuse size. |   |          |          |          |               |
| Cable cross-sections   |   |          |          |          |               |
|  | solid or stranded mm <sup>2</sup>                 | 0,75-2,5 | 0,75-2,5 | 0,75-2,5 | 1-2,5         |
|  | flexible mm <sup>2</sup>                          | 0,75-2,5 | 0,75-2,5 | 0,75-2,5 | 0,75-2,5      |
|  | flexible with multicore cable end mm <sup>2</sup> | 0,5-1,5  | 0,5-1,5  | -        | 0,75-2,5      |
| Cables per clamp   |   | 2        | 2        | 2        | 2             |

\*1 Suitable for: earthed-neutral systems, overvoltage category I to IV, pollution degree 3 (standard-industry):  $U_{imp} = 8kV$ . Data for other conditions on request

### Data according to CSA, UL and CUL

| Auxiliary Contacts                      | Type      | J73KN-B | J73KN-C | J73KN-D | J74KN-B-TP... |
|---|-----------|---------|---------|---------|---------------|
| Rated operational current „General Use“ | A         | 10      | 10      | 10      | 10            |
| Rated operational voltage               | max. V AC | 600     | 600     | 600     | 600           |
| Auxiliary Contacts                      |           | A600    | A600    | A600    | A600          |

## Contactors and Accessories

### Wiring diagrams

#### Auxiliary contact blocks

J73KN-B-10

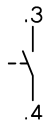

J73KN-B-01

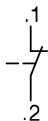

J73KN-C-11S\*1

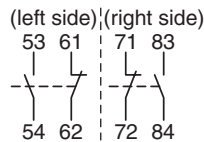

#### Pneumatic timer

on-delayed  
J74KN-B-TP...DA

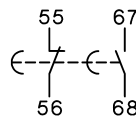

off-delayed  
J74KN-B-TP...IA

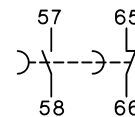

J73KN-D-11

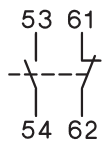

J73KN-D-11S

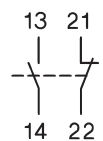

J73KN-D-22

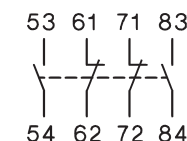

\*1 Correct terminal marking is given by mounting

■ Dimensions

AC operated

- J7KN-10...
- J7KN-10-4
- J7KN-14...
- J7KN-14-4...
- J7KN-18...
- J7KN-18-4...
- J7KN-22...
- J7KN-22-4...

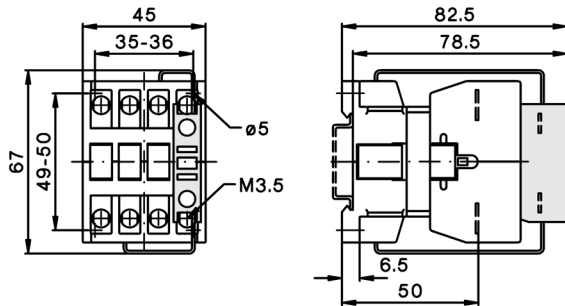

DC operated

- J7KN-10...D
- J7KN-14...D
- J7KN-18...D
- J7KN-22...D

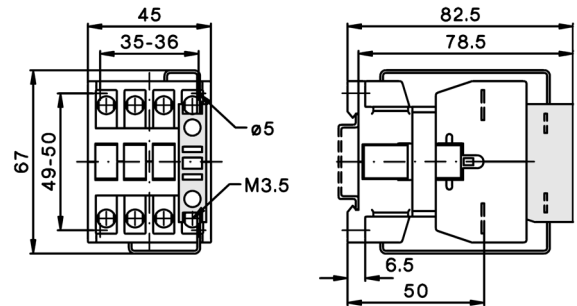

- J7KNG-10...
- J7KNG-14...
- J7KNG-18...
- J7KNG-22...

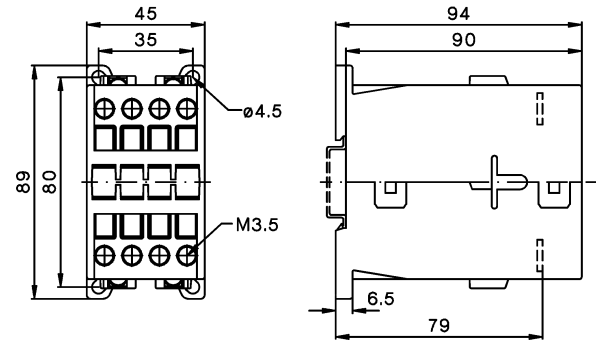

- J7KN-24...
- J7KN-32...
- J7KN-40...

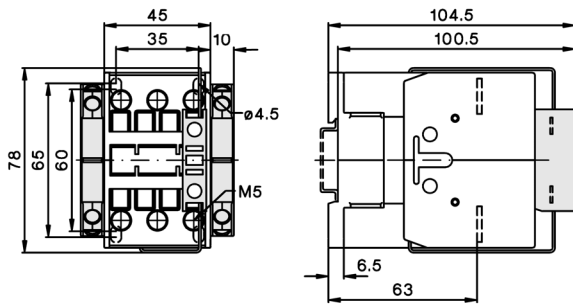

- J7KN-24...D
- J7KN-32...D
- J7KN-40...D

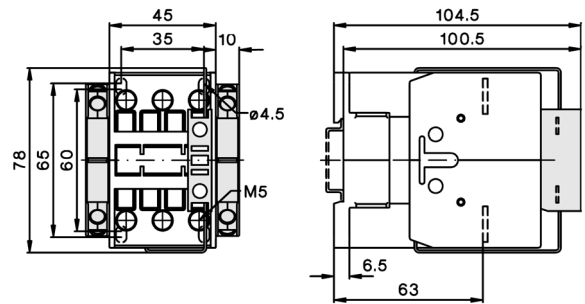

- J7KN-50...
- J7KN-62...
- J7KN-74...

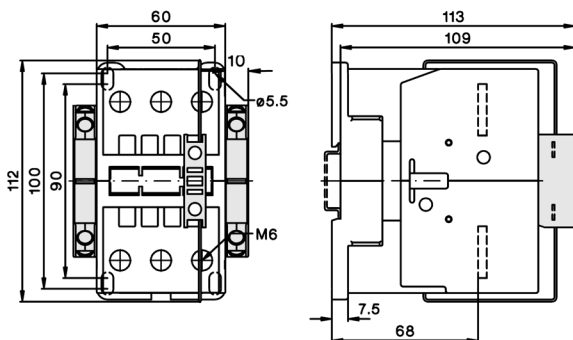

- J7KN-50...D
- J7KN-62...D
- J7KN-74...D

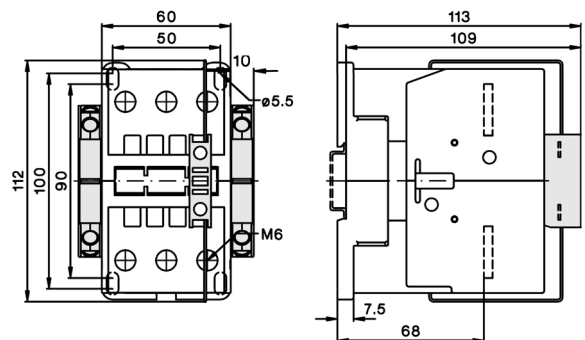

Low voltage switch gear

AC and DC operated

J7KN-85...  
J7KN-110...

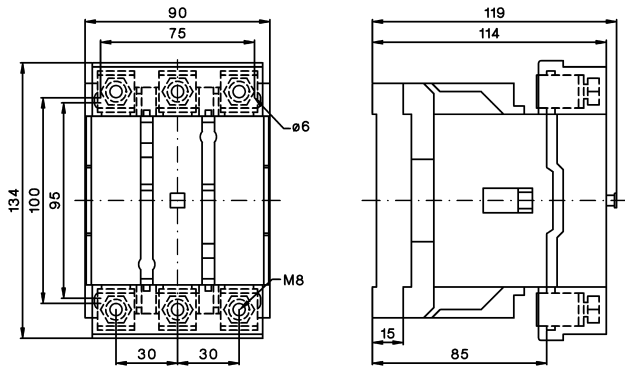

J7KN-200...

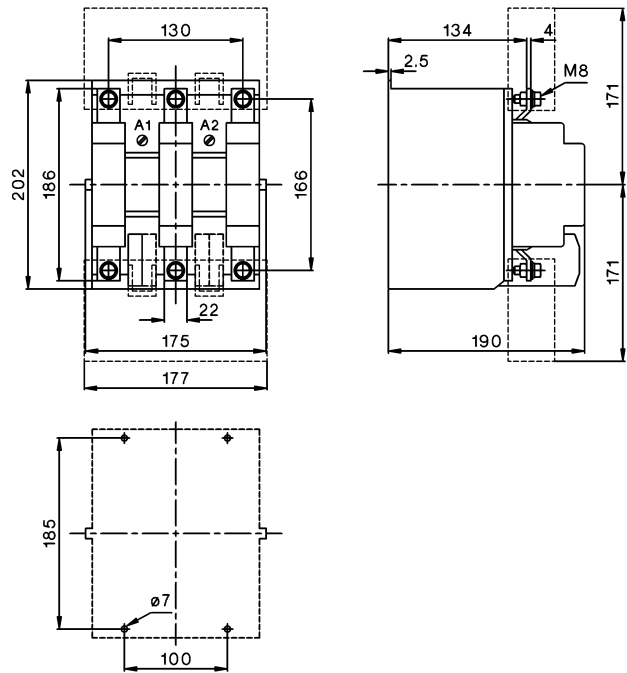

J7KN-151...  
J7KN-176...

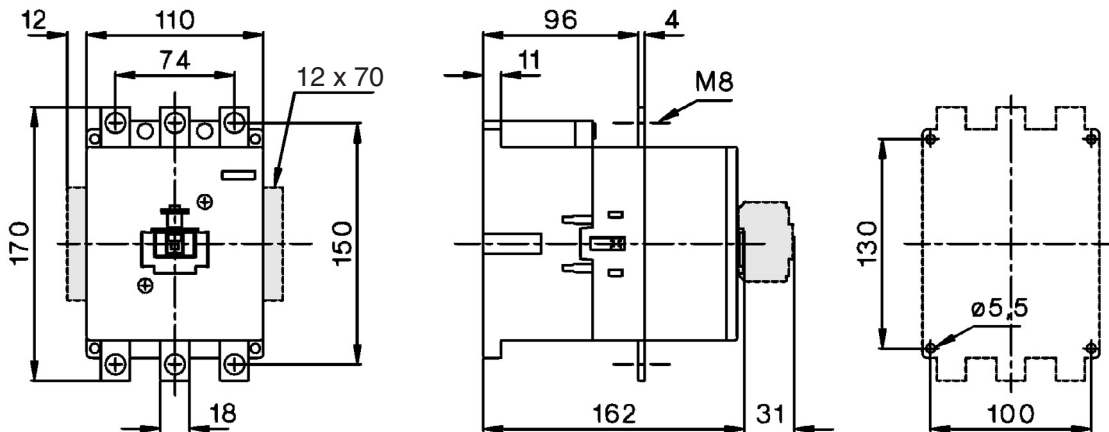

Pneumatic timer

J74KN-B-TP...

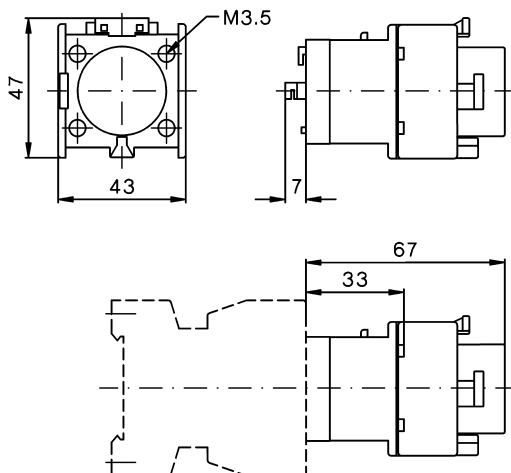

Auxiliary contact blocks

J74KN-A-VG

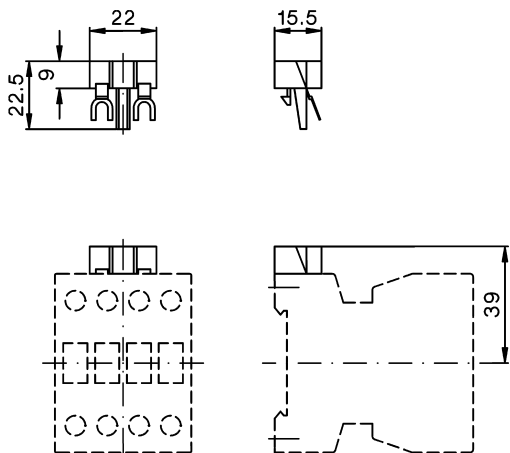

J74KN-B-VG

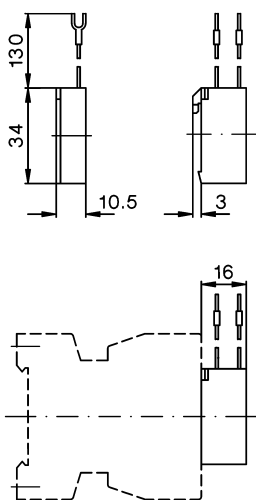

J74KN-A-RC

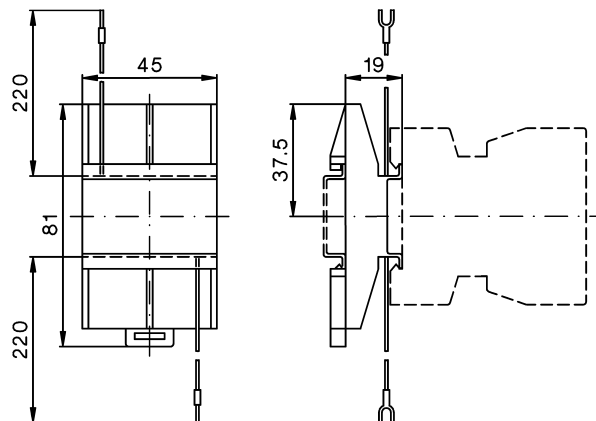

J74KN-B-RC

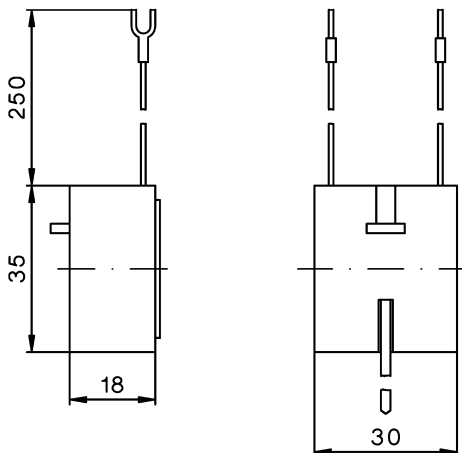

Position of Terminals

AC operated

J7KN-10-10  
to  
J7KN-22-10

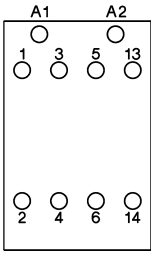

J7KN-10-01  
to  
J7KN-22-01

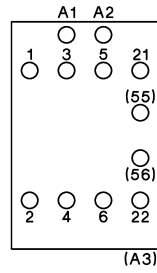

J7KN-24  
J7KN-32  
J7KN-40

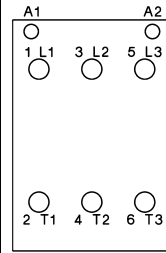

J7KN-50  
J7KN-62  
J7KN-74

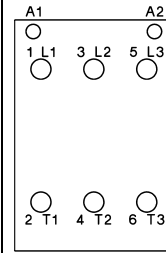

J7KN-85-22  
J7KN-110-22

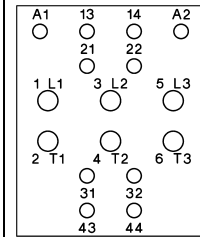

J7KN-200-22

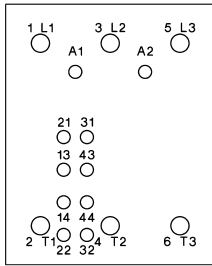

DC operated with double winding coil

J7KN-10-10...D  
J7KN-14-10...D  
J7KN-18-10...D  
J7KN-22-10...D

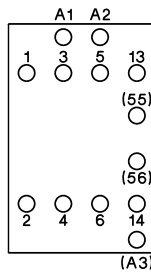

J7KN-10-01...D  
J7KN-14-01...D  
J7KN-18-01...D  
J7KN-22-01...D

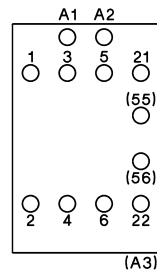

J7KN-24...D  
J7KN-32...D  
J7KN-40...D

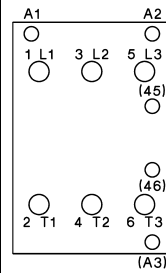

J7KN-50...D  
J7KN-62...D  
J7KN-74...D

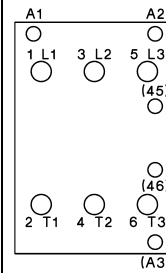

J7KN-85-21...D  
J7KN-110-21...D

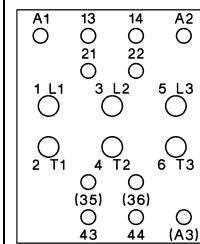

AC and DC operated

J7KN-151  
J7KN-176

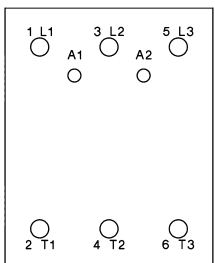

DC operated

J7KNG-10-10  
J7KNG-14-10  
J7KNG-18-10  
J7KNG-22-10

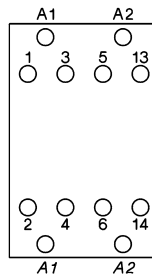

J7KNG-10-01  
J7KNG-14-01  
J7KNG-18-01  
J7KNG-22-01

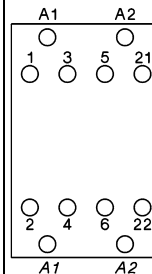

ALL DIMENSIONS SHOWN ARE IN MILLIMETERS.

To convert millimeters into inches, multiply by 0.03937. To convert grams into ounces, multiply by 0.03527.